

# NETZSCH

Proven Excellence.

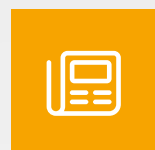

Areas of application

## Environmental & Energy

Processes, Markets and Applications









Pumps & Systems

# EXPERTISE CREATES TRUST

## INTELLIGENT SOLUTIONS FOR A CLEAN ENVIRONMENT

**Environmental protection, water management, energy technology – the challenge lies not only in the development of modern technology, but also in the development of the necessary expertise how to produce responsibly, dealing with raw materials, climate and environment. We are prepared for these versatile tasks.**

**The Businessfield Environmental & Energy serves the following industries:**

- |   |   |   |
|---|---|---|
|  <b>Cleaning waste water</b>   |  <b>Renewable energies</b> |  <b>Purification of water &amp; drinking water</b> |
|  <b>Agriculture</b>            |  <b>Biogas</b>             |  <b>and much more</b>                              |
|  <b>Construction industry</b> |  <b>Marine equipment</b>  |   |

### **What we offer**

In the business field “Environment & Energy” we provide positive displacement pumps as conveying systems for all media in environmental technology. Due to their regulating characteristics, these pumps ensure a safe, reliable and efficient process. Here we differentiate between the NEMO® progressing cavity pumps, TORNADO® rotary lobe pumps, NOTOS® multi screw pumps and PERIPRO® peristaltic pumps.

### **Who we are**

NETZSCH Pumps & Systems is a family-run, medium-sized company based in Waldkraiburg, founded in 1962. Worldwide, over 3,000 employees work across five development and production sites, as well as in 30 sales companies and over 200 agencies – NETZSCH is always close by.

### **Why you succeed with us**

We select the technically optimal pump for every application. You receive a cost-effective, reliable and precisely tailored pumping system. Our range is complemented by grinding systems and accessories.





# Waste water treatment plant

We offer **NEMO® progressing cavity pumps**, **TORNADO® rotary lobe pumps** and **PERIPRO® peristaltic pumps** in various designs and materials – each specifically engineered to meet the requirements of wastewater treatment plants. Our pumps handle low-viscosity and abrasive slurries just as reliably as media with a high solids content, such as dewatered sludge. **NEMO® hopper pumps** with a screw conveyor or with aBP-Module® are particularly suitable for preventing bridging.

Thanks to their compact design, **TORNADO® rotary lobe pumps** are ideal for confined installation spaces. They are just as robust as progressing cavity pumps and are also suitable for media containing larger solids.

**NETZSCH grinders** protect pipes and pumps and – together with the extensive range of accessories – contribute to the high process reliability of the entire plant.

**PERIPRO® peristaltic pumps** handle media containing corrosive or highly abrasive substances, such as flocculants and precipitants, with ease. Their robustness is due to durable materials, integrated ball bearings and large rollers. This reliably prevents leaks during operation.

For water treatment, we offer two different versions of the **PERIPRO® peristaltic pumps**:

- Industrial version for non-corrosive media
- Chemical version for corrosive media

#### Flow rate and pressure range

- Flow rates up to 39,000 l/h
- Pressures up to 10 bar
- Temperatures up to 80 °C
- Models for industrial, chemical and food production applications



PERIPRO® peristaltic pumps

# Construction industry & construction

## EXTREMELY ROBUST PUMPS TO ENSURE SUCCESS

The high pressure in terms of deadlines and costs in construction make it important for pumps to run perfectly and also to be capable of efficient operation. In addition, construction primarily involves dealing with granular and binding media containing solids. These are generally difficult for pumps to convey. NETZSCH self-priming, rotating positive displacement pumps are well-prepared for these difficult tasks. They are wear-resistant thanks to the material coatings and have an extremely high resistance to solid contents. They ensure reliable operation in construction. **NEMO® progressing cavity pumps** offer a particularly reliable solution for highly abrasive and solids-laden media, such as concrete slurry and cement slurries. Their continuous, gentle pumping principle ensures consistent flow even with high solids content and difficult flow characteristics. At the

same time, robust materials and high wear resistance ensure a long service life and low maintenance requirements. Thanks to their flexible design, the pumps can be optimally adapted to changing requirements on the construction site, thus ensuring efficient and safe operation.

### Your medium – We are prepared for everything

- Waste water from concrete production
- Concrete suspension
- Drilling sludge
- Gypsum suspension
- Gypsum slurry
- Adhesive bases
- Waste water
- Cement suspension

### NEMO®

#### progressing cavity pumps

- Capacities up to 400 m<sup>3</sup>/h
- Pressures up to 48 bar
- Temperatures from -20 °C up to +200 °C
- Pump types:
  - Flange pumps
  - Mixing pumps
  - High pressure pumps
  - Hopper pumps
  - Immersion pumps
  - Pumps for special applications



# Biogas plants

## PROCESS ADAPTION FOR HIGHER ENERGY PRODUCTION

The inhomogeneous, liquid or solid, organic substances are decomposed through the use of microorganisms and, thereby, used to generate energy. Depending on the process sequence, it is necessary that the biomass is continuously fed to the fermenters.

Here, pump systems are required to convey the large quantity and sizes of grain in the solids flux without problems. **NEMO® progressing cavity pumps** as well as **TORNADO® rotary lobe pumps** are used for this application, sometimes combined with NETZSCH grinders.

### Advantages

- Variable, modular system
- Robust, compact and powerful pumps
- Pumping media with high solids content
- Large range of materials
- The correct joint for every application
- Mechanical seal as standard, further seals as an option

### Typical media

- Bio waste
- Biomass
- Food waste
- Grain
- Haylage
- Manure
- Pomace
- Slaughterhouse waste



NEMO® B.Max

# Marine and ship equipment

Whether as a fuel or gear pump, hydraulic pump, bilge and mud pump or as pump for loading or unloading oil tankers, commercial or naval ships.

NETZSCH pumps are wide spread. **NEMO® progressing cavity pumps**, **TORNADO® rotary lobe pumps** as well as **NOTOS® multi screw pumps** can be found in the engine room or on deck as transfer pumps. Highly viscous media such as heavy oil are pumped as reliable as low viscosity media such as diesel oil, gasoline, salt and fresh water.

## NOTOS® multi screw pump

- Flow rate up to 2500 m<sup>3</sup>/h
- Pressure rate up to 160 bar
- Viscosities up to 200.000 cSt
- Temperature up to 320 °C
- Pump types:
  - 2 Screw pump
  - 3 Screw pump
  - 4 Screw pump

## Typical media

- Anchor chains oil
- Diesel fuel oil
- Fuel oil
- Lubricating oil
- Residual oil
- Sludge
- Various chemicals
- Waste oil
- Waste water (grey and black water)
- Urea
- Magnesium hydroxide sludge



The NOTOS® pump family

TORNADO® T1 XLB

NEMO® BY

## Technical details NOTOS®



# NEMO® Progressing cavity pumps

POWERFUL FOR OUR ENVIRONMENT

## NEMO® BY in block design

Compact design with directly flanged drive. It is distinguished by its low investment, operating and maintenance costs. Four rotor/stator geometries for optimum performance with every kind of application.

### Technical details



## The FSIP® design

The FSIP® design enables a particularly service-friendly maintenance without dis-assembling of the pump from the pipeline. By easier access to all rotating parts through cartridge joint and mechanical seals the maintenance is reduced. The downtimes and the associated costs are reduced. In addition, it reduces the required installation space, since the stator is removed laterally. The FSIP® design is offered in modification sets. So you can upgrade also existing pumps with lower costs.

### Technical details

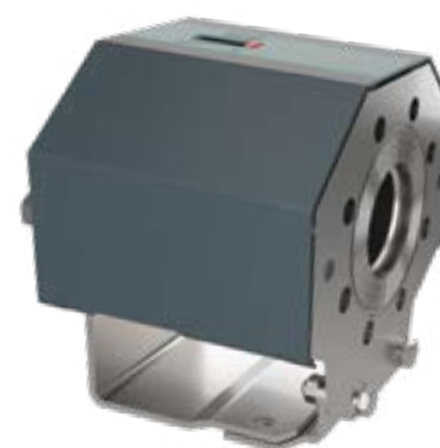

## The xLC® stator adjustment unit

The xLC® stator adjustment unit makes it possible to reset the iFD-Stator® 2.0 several times before it eventually has to be replaced due to wear, thereby prolonging stator life significantly. The function of the xLC® unit is based on the iFD-Stator® 2.0. The xLC® unit is attached to the flange of the elastomer part of the stator and can compress or stretch it.

### Technical details



## NEMO® SY with bearing housing and drive shaft

In the case of wear the elastomer part of the stator can be compressed to restore the pretension between the rotor and stator ensuring an efficient sealing line. Depending on the application lifetime can be tripled or extended even further.

The design with bearing housing and drive shaft means it can be used with all types of drive. Four rotor/stator geometries for optimum performance for the respective application. Also available in FSIP® design.

# NEMO® Progressing cavity pumps

POWERFUL FOR OUR ENVIRONMENT

## NEMO® C.Pro

**Mini dosing pump in plastic design**

High dosing accuracy (deviation of < 1 %).  
Compact design with directly flanged drive.

Technical details



## NEMO® BO/BS

**in block design with directly flanged drive or NEMO® SO/SS with bearing housing and drive shaft**

Housing with rectangular/square feed hopper and coupling rod with conveying screw with compression chamber for improved product feeding into the conveying elements.

Technical details



## NEMO® BF option with aBP-Module®

**in block design with directly flanged drive or with bearing housing and free shaftend**

Housing with enlarged, rectangular feed hopper and coupling rod with horizontally positioned conveying screw for optimum product feeding into the conveying elements. Optional with aBP-Module® to prevent bridging.

Technical details



## NEMO® B.Max

**in block design with directly flanged drive or with bearing housing and drive shaft end**

Housing with large, rectangular feed hopper\*, coupling rod with horizontally positioned conveying screw for optimum product feeding into the conveying elements. The additional, hydrodynamically designed flushing stud installed on the hopper housing ensures the substrates are fed and mixed optimally for the biomass.

Technical details



\*Technical notes: the hopper dimensions can be adjusted to suit the specific application.

# TORNADO® Rotary lobe pumps

POWERFUL, ROBUST, COMPACT

The self-priming, valveless **TORNADO® rotary lobe pumps** are powerful and perfectly tailored to individual requirements. They are suitable for the continuous, gentle transfer and speed-proportional dosing of almost all fluids.

## TORNADO® Rotary lobe pumps

- Capacities up to 1400 m<sup>3</sup>/h
- Pressures up to 12 bar
- Temperatures up to 100 °C
- Pump types:
  - For the environment, energy and agriculture
  - Versatile TORNADO® mobile pumps
  - Pumps for specialist applications

## TORNADO® Mobil

The NETZSCH **TORNADO® Mobil** is ideal for the flexible use of pumps in outdoor applications. It consists of a mobile, diesel-powered **TORNADO® rotary lobe pump** and can handle large volumes of dirty water and sludge regardless of local conditions. It is therefore frequently used in disaster relief operations. Smaller models are also available.

## Broad range of applications

The pumps are primarily used with media that have the following features:

- With and without solids
- Low to high viscosity
- Thixotropic and dilatant
- Shear sensitive
- Abrasive
- Non-lubricating and lubricating

## Technical details

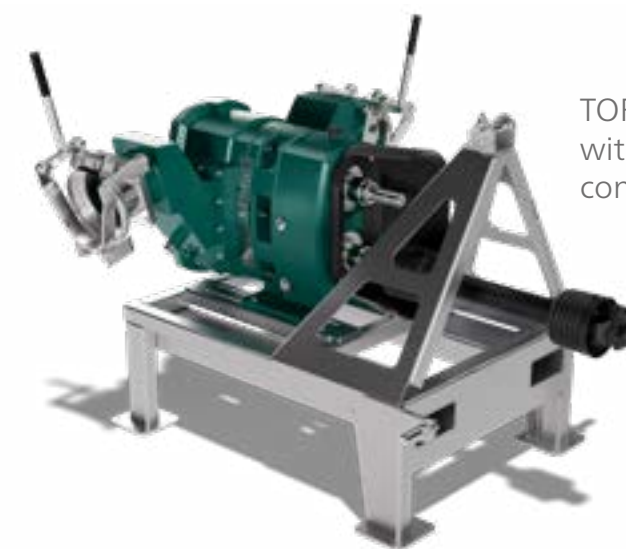

TORNADO®  
with PTO  
connection



TORNADO® T1 XLB



Technical details

TORNADO® Mobil

# Grinding systems

SO THAT EVERY COARSE MATERIAL IS PUMPABLE

Powerful grinding systems are used to protect plant equipment and pump units. They grind foreign matter down to a pumpable consistency, thereby reliably preventing blockages and clogging in pump systems and pipes.

## M-Ovas®

### Cutting plate macerator

In wastewater treatment, contaminants in the wastewater stream are fed through the special housing design of the cutting plate and shredded by rotating blades. The unit is available in two sizes with a throughput of up to 300 m<sup>3</sup>/h and a total solids (TS) content of up to 12%, and is characterised by its high ease of maintenance.

#### Technical details



M-Ovas®  
cutting plate macerator

## N.Mac®

### Double shaft grinder

The N.Mac® double shaft grinder breaks down coarse and solid contaminants in liquid media. Available in various sizes, it is suitable for applications ranging from wastewater treatment and biogas substrates to food and fruit waste. Different housing variants allow for installation in sewers or pipework systems, prevent pipe blockages and protect downstream equipment such as pumps.

#### Channel

#### Inline



N.Mac®  
double shaft grinder

# Service and Support

FOR US, PARTNERSHIP DOES NOT END WITH THE PURCHASE

We know no limits when it comes to offering our customers first rate service. Our promise is to deliver Proven Excellence – outstanding performance in all areas.



## Personal support

- 24/7 worldwide support from experienced staff
- Personalised advice tailored to your needs
- Global network of service and stock locations
- Fast, efficient assistance – including on-site support
- Ensuring smooth pump operation



## Spare parts

- NETZSCH genuine parts of the highest manufacturer quality
- Consistent quality standards worldwide in accordance with ISO 9001
- Reliable operation with minimal downtime
- Reduced maintenance costs
- Optimal long-term performance of the pumps



## Technical training

- Practical training delivered by technical specialists
- Training sessions held at our centres, online or directly at your premises
- Cost savings through more efficient operation
- Improved pump performance
- Prevention of errors during commissioning, maintenance and repair

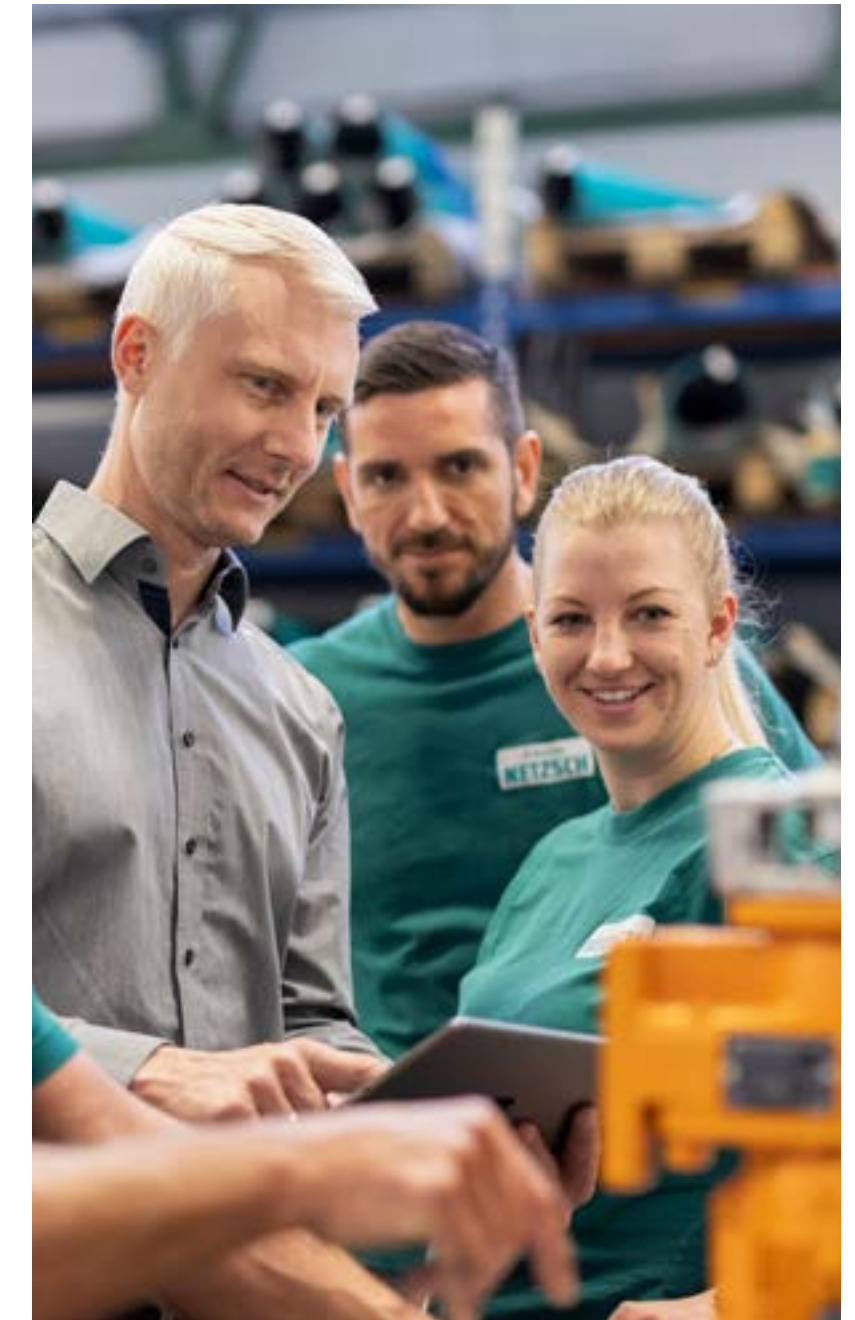

**More information on  
our service and support  
can be found here:**

The owner-managed NETZSCH Group is a leading global technology company specializing in mechanical, plant and instrument engineering.

Under the management of Erich NETZSCH B.V. & Co. Holding KG, the company consists of the three business units Analyzing & Testing, Grinding & Dispersing and Pumps & Systems, which are geared towards specific industries and products. A worldwide sales and service network has guaranteed customer proximity and competent service since 1873.

The NETZSCH Business Unit Pumps & Systems offers NEMO® progressing cavity pumps, TORNADO® rotary lobe pumps, NOTOS® multi screw pumps, PERIPRO® peristaltic pumps, macerators/grinders, dosing technology and equipment that are custom built for challenging solutions for different applications globally.

# Proven Excellence. ■

NETZSCH Pumpen & Systeme GmbH  
Geretsrieder Straße 1  
84478 Waldkraiburg  
Germany  
Phone: +49 8638 63-0  
info.nps@netsch.com  
www.pumps-systems.netsch.com