

NETZSCH

Proven Excellence.



Products & Accessories

PERIPRO[®] Peristaltic Pumps

Robust design for demanding applications

Pumps & Systems



NETZSCH Pumps & Systems

YOUR GLOBAL SPECIALIST FOR CONVEYING
COMPLEX MEDIA

NETZSCH Pumps & Systems, the global specialist for conveying complex media.

We promise you Proven Excellence - outstanding performance in all areas.

Designed specifically for difficult conveying situations, the products range from very small industrial metering pumps to high volume pumps for applications in the oil and gas sector or the mining industry. Our **NEMO® progressing cavity pumps, TORNADO® rotary lobe pumps, NOTOS® multi screw pumps, PERIPRO® peristaltic pumps, grinders, dosing equipment and accessories** offer customised, reliable solutions for your applications all over the world.

The high level of quality of our products and original spare parts is based on over 70 years of experience in development, production and distribution. We manufacture more than 75,000 pumps per year, which works to your benefit as our customer: The high level of reliability allows you to reduce your maintenance costs and take preventive action against unplanned downtime.

Our service and support does not end with the purchase. On the contrary – it starts well before an order is placed. From consultation, maintenance and spare parts to repairs and modernisation of your pump, we support you from the outset. And with our worldwide service network, we are here to help around the clock in the event of an emergency.

All NETZSCH pumps can be used in a wide range of applications, for example:

- Bonding and sealing
- Chemicals
- Dosing
- Environmental technology
- Food and beverages
- Marine applications
- Mining
- Oil & gas production and transfer
- Paints and coatings
- Paper industry
- Pharmaceuticals and cosmetics
- Renewable energies
- Water and wastewater treatment

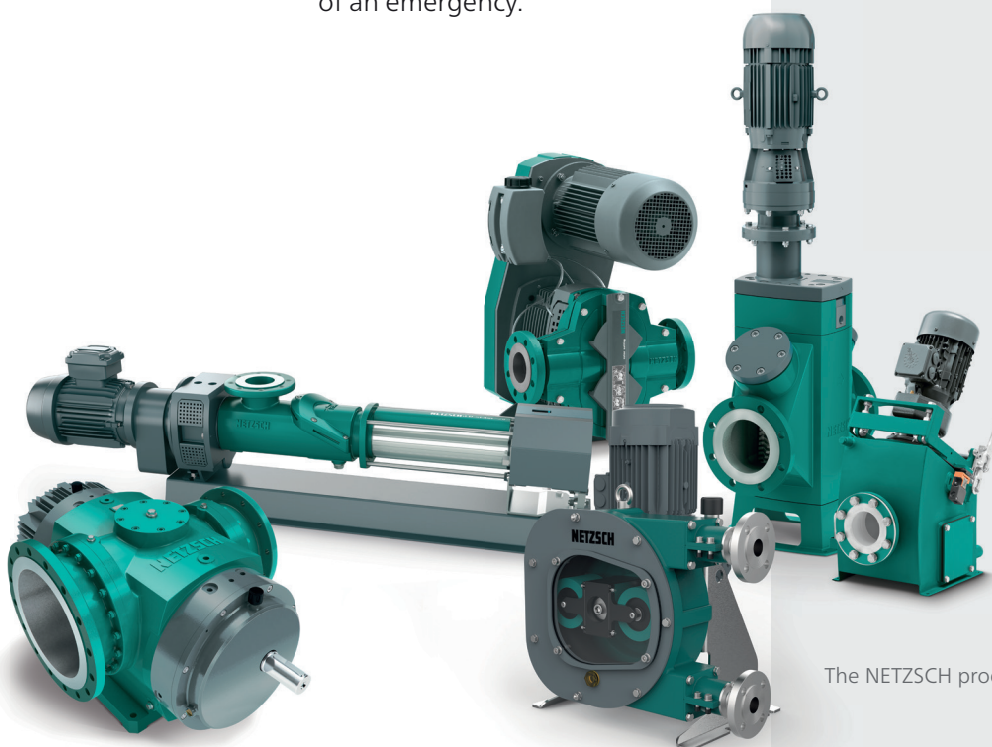

The NETZSCH product portfolio

PERIPRO[®] Pumps

HIGH PERFORMANCE PERISTALTIC PUMPS WITH LARGE ROLLERS FOR A LONGER SERVICE LIFE

NETZSCH technology for peristaltic pumps

- Excellent abrasion resistance
- Extremely high suction capability
- No valves or mechanical seals
- Industrial, corrosion resistant and food safe models
- Dosing accuracy: $\pm 1\%$
- Up to 70 % solids content in the conveyed media

Advantages of PERIPRO[®] pumps

- Very long pump service life and excellent performance
- Robust pump technology
- Easy hose replacement
- Low starting torque
- High resistance to dry running
- Lower energy costs
- Low lubricant requirement

Ideal for difficult media

- Abrasive media: lime milk, activated carbon, slurries, etc.
- Corrosive media: sodium hypochlorite, ferric chloride, hydrochloric acid, etc.
- Viscous media: adhesives, greases, creams, resins, etc. (water based)
- Delicate media: latex, polymers, flocculants, food, etc.

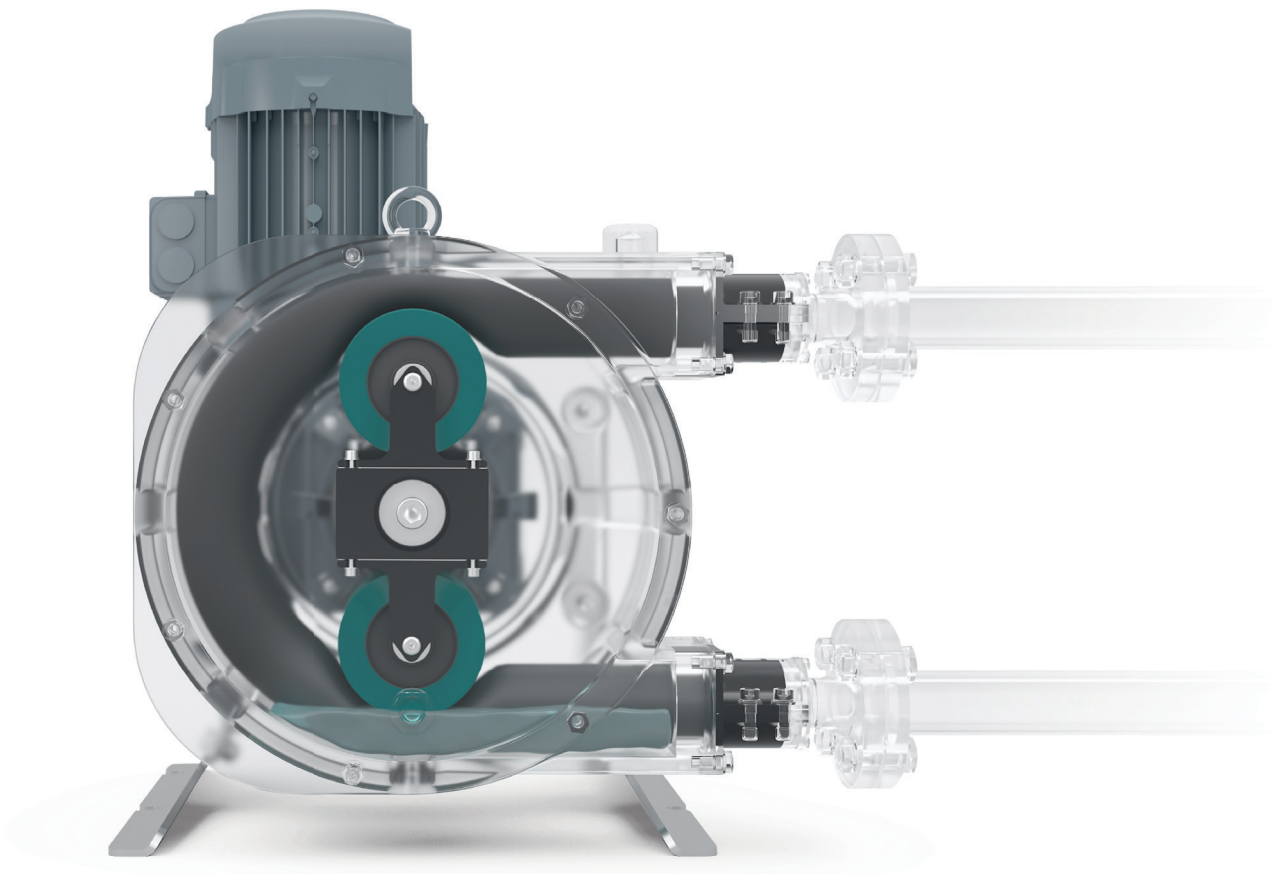

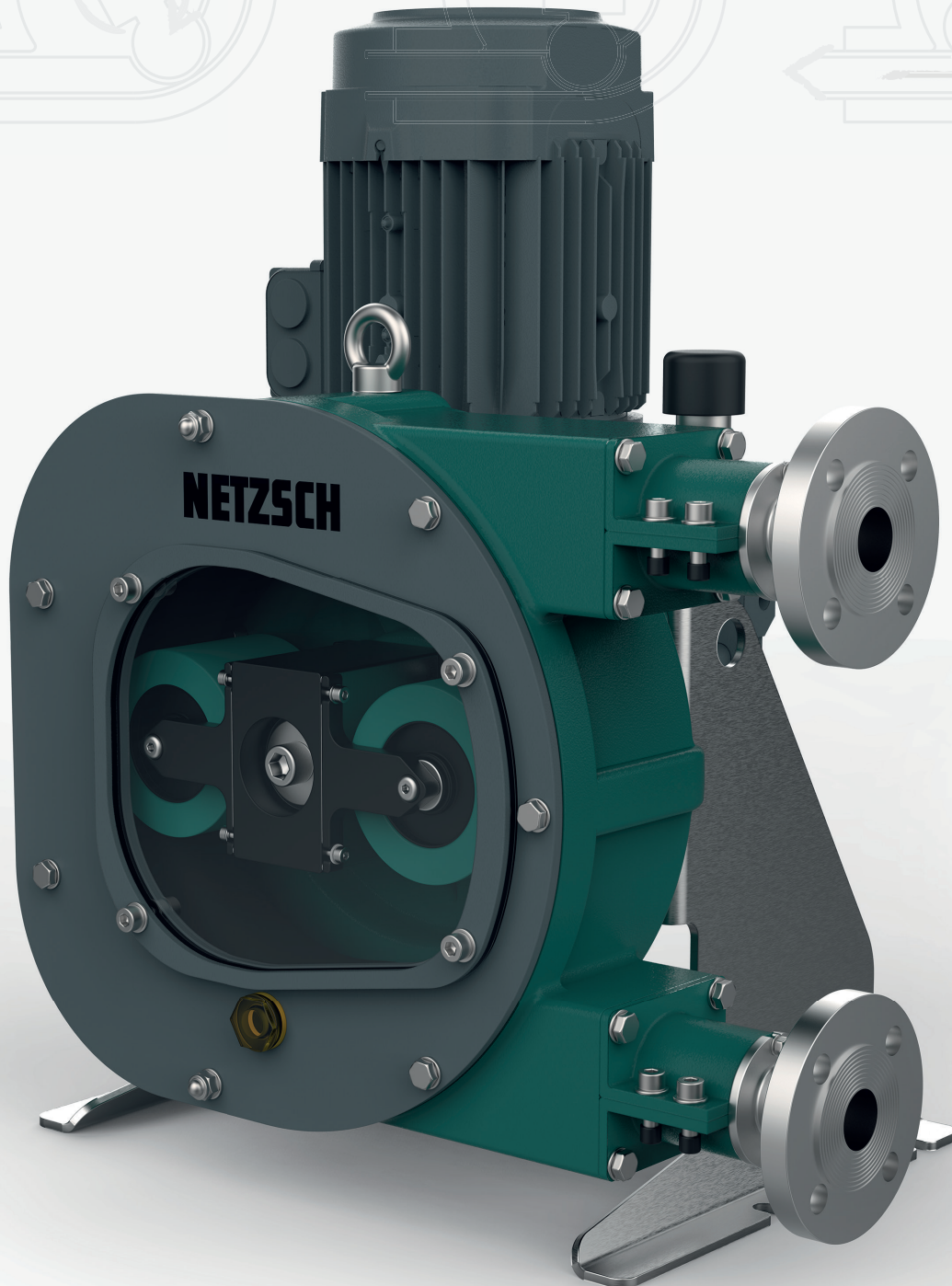
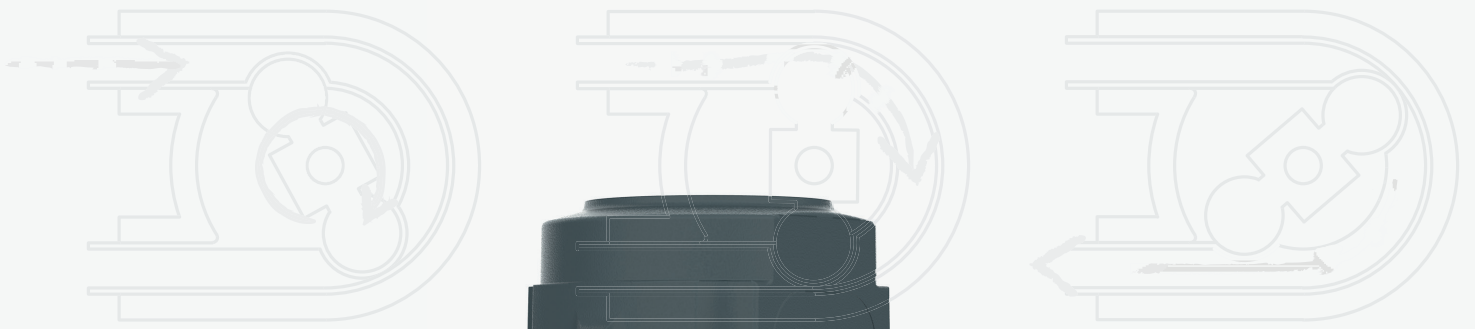

Up to 30 % energy savings



Highly robust design
with XXL rollers



90 % less lubricant



Only one wear part

The PERIPRO® Design

WHAT MAKES THIS PUMP SO DURABLE?

1

Low hose wear

High quality hose with unique manufacturing process. Extruded inner layer, highly compacted textile reinforcement and precision manufactured outer layer. Available materials that are compatible with all types of products and working conditions.

2

Robust design

Fast and easy installation, commissioning and maintenance. Innovative pump design that facilitates installation and hose replacement. Maintenance free pump and up to 90 % less lubricant consumption compared to conventional pumps.



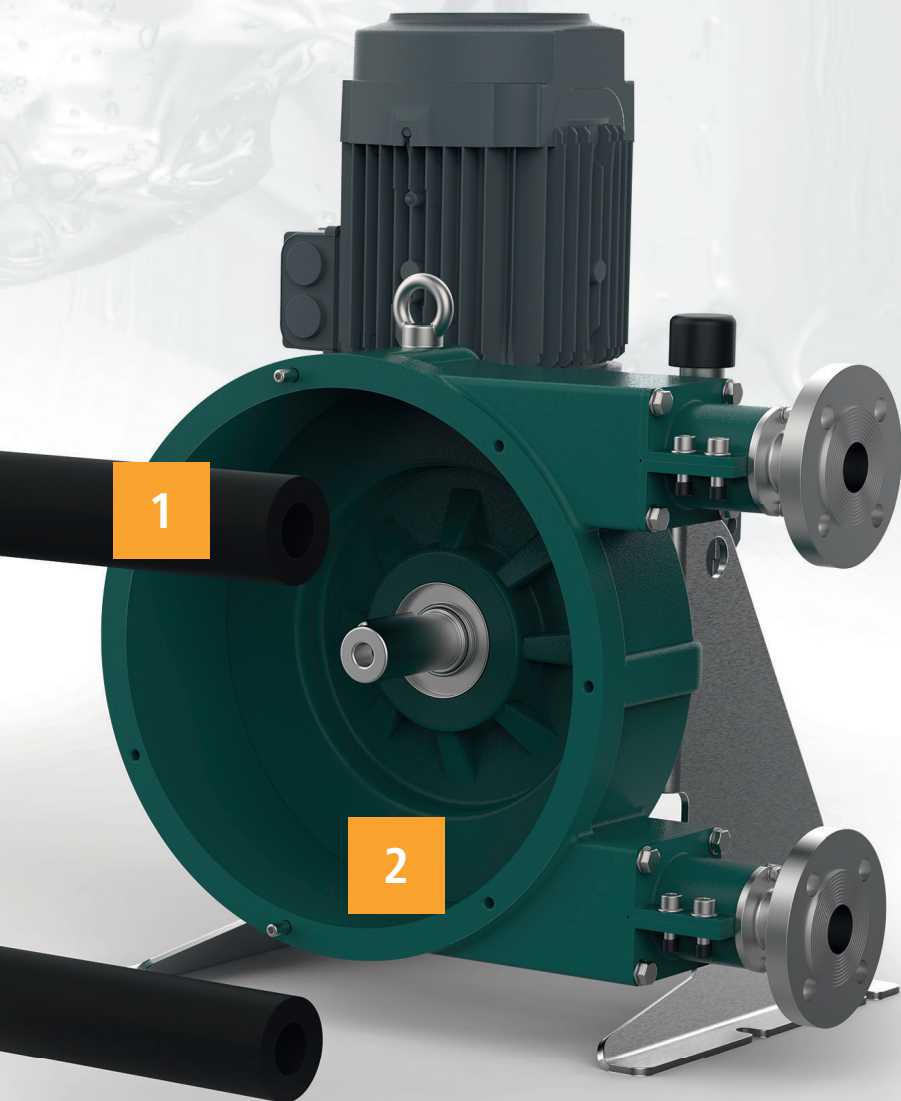

3

Bearings

Integrated oversized bearings to resist the axial loads. Reliable connection system and highly robust materials.

4

Rollers

Excellent compression of the hose without friction. Up to 30% lower energy consumption and longer hose service life due to the roller size. Easier operation with minimum starting torque and a very wide frequency range.



In summary: PERIPRO® pumps are easy to operate while offering excellent energy savings, a longer service life and greater durability of the hose.



See the
3D model
here

The Four Versions

TO SUIT YOUR APPLICATION



Industrial version

Robust design for conveying abrasive and aggressive media



- High durability and maximum serviceability
- Robust design
- Service-friendly conveying of abrasive and aggressive media like ceramic slip or mortar



Technical details



Food version

Contamination free conveying of food and particularly easy cleaning

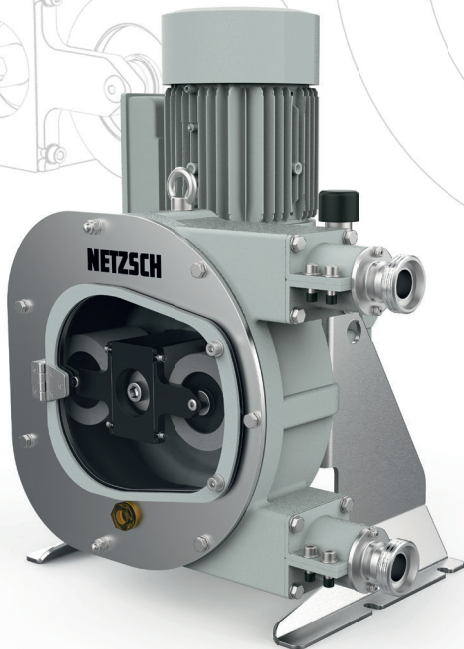

- The hatch in the cover allows for removal of the rollers and even easier cleaning of the pump
- Hose made of food grade FDA-certified nitrile
- Typical applications: transfer of viscous sauces and juices or supplying of filling machines



Chemical version

High level of reliability for conveying and dosing corrosive media



- Sensor for hose leakage
- Only one part in contact with the medium, chemically resistant TEFZEL® coated housing
- Transferring and dosing of highly abrasive media like titanium dioxide or resins



Technical details



Technical details

PERIPRO[®] Tube Pump

EFFICIENT, HIGH-PERFORMANCE AND EASY TO MAINTAIN



Industrial Tube Pump

Precise dosing of small volumes

NEW

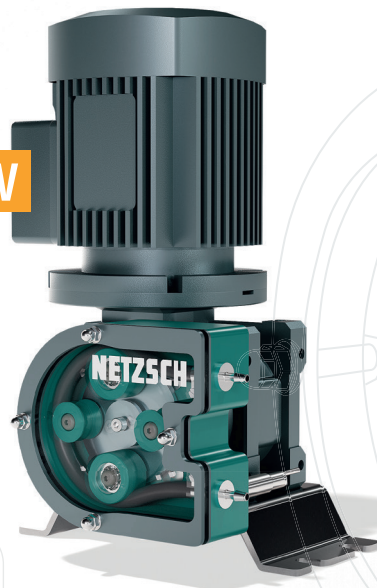

- Heavy duty pump
- Lip seals and seals on the housing provide a secure seal to the atmosphere
- Big rollers ensure minimal friction between rollers and tube



Technical details

Advantages of the PERIPRO® Tube Pump

- High suction applications up to 8 m.w.c and indefinite dry running
- Easy conveying of products containing solids or in multiphase state
- Highly viscous products up to 10.000 cPs
- Pressure variations do not affect pump performance
- Simple tube replacement
- Sensor to detect tube rupture

Typical applications

- Sodium hypochlorite
- Polymer
- Lime milk
- Active carbon
- Calcium hydroxide
- Acids (Hydrochloric, Ferric chloride, sulphuric acid, etc.)
- Additives in food industry



The PERIPRO® Tube Pump Design

1

Hermetic sealing

The pump is designed to prevent leakages and environmental damage. Constructed with anticorrosive materials, it ensures durability and reliability even in the hardest conditions.

2

Rollers

Heavy duty roller design with integrated bearings and two roller guides. Easy tube replacement at very low maintenance cost.



1

2





3

3

Tube

With the different tube materials, it is possible to handle various applications, including corrosive or highly viscous products.

4

Leakage sensor

A capacitive sensor is always installed to detect tube rupture at an early stage, guaranteeing instant action to avoid further damage.

4



See the 3D model here

Service and Support

“FOR US, PARTNERSHIP DOES NOT END WITH THE PURCHASE”

We know no limits when it comes to offering our customers first rate service. Our promise is to deliver Proven Excellence – outstanding performance in all areas.



Unlimited personal support

Our experienced employees provide support and advice worldwide and around the clock, always tailored to your specific requirements. With our global network of service locations and warehouses, we guarantee prompt and efficient support, including on site and in person, so your pumps can always run smoothly.



Spare parts

NETZSCH original spare parts stand for the highest manufacturing quality. We ensure reliable quality through worldwide implementation of uniform standards as per DIN EN ISO 9001. This enables reliable operation of your pumps with little downtime and low maintenance costs, and therefore continued optimum performance.



Technical training

The specialists from our Technical Service provide practical training for your employees at the NETZSCH training centres, online or at your facility. This allows you to benefit from cost savings and increased pump efficiency and to avoid mistakes during commissioning, maintenance or repairs.

More information on our service and support can be found here:





The owner-managed NETZSCH Group is a leading global technology company specializing in mechanical, plant and instrument engineering.

Under the management of Erich NETZSCH B.V. & Co. Holding KG, the company consists of the three business units Analyzing & Testing, Grinding & Dispersing and Pumps & Systems, which are geared towards specific industries and products. A worldwide sales and service network has guaranteed customer proximity and competent service since 1873.

The NETZSCH Business Unit Pumps & Systems offers NEMO® progressing cavity pumps, TORNADO® rotary lobe pumps, NOTOS® multi screw pumps, PERIPRO® peristaltic pumps, macerators/grinders, dosing technology and equipment that are custom built for challenging solutions for different applications globally.

Proven Excellence. ■

NETZSCH Pumpen & Systeme GmbH
Geretsrieder Straße 1
84478 Waldkraiburg
Germany
Phone: +49 8638 63-0
info.nps@netsch.com
www.pumps-systems.netsch.com

NETZSCH Asia Pacific Pte. Ltd.
Singapore
Phone: +65 6863 4453
info.nap@netsch.com

PT. NETZSCH Indonesia
Jakarta, Indonesia
Phone: +62 21 296 75 385
info.nij@netsch.com

NETZSCH Thailand Ltd.
Bangkok, Thailand
Phone: +66 2 152 7325
info.ntb@netsch.com

NETZSCH (Malaysia) Sdn Bhd
Shah Alam, Malaysia
Phone: +60 3 5885 9201
info.nmk@netsch.com

NETZSCH Vietnam Limited
Ho Chi Minh City, Vietnam
Phone: +84 28 6281 1042
info.nvh@netsch.com

NETZSCH Australia Pty Ltd
Head Office Brisbane
Phone: +61 7 3488 8183
Regional Office Sydney
Phone: +61 2 9641 2840
nas@netsch.com



NETZSCH®

www.netsch.com