

NETZSCH

Proven Excellence.

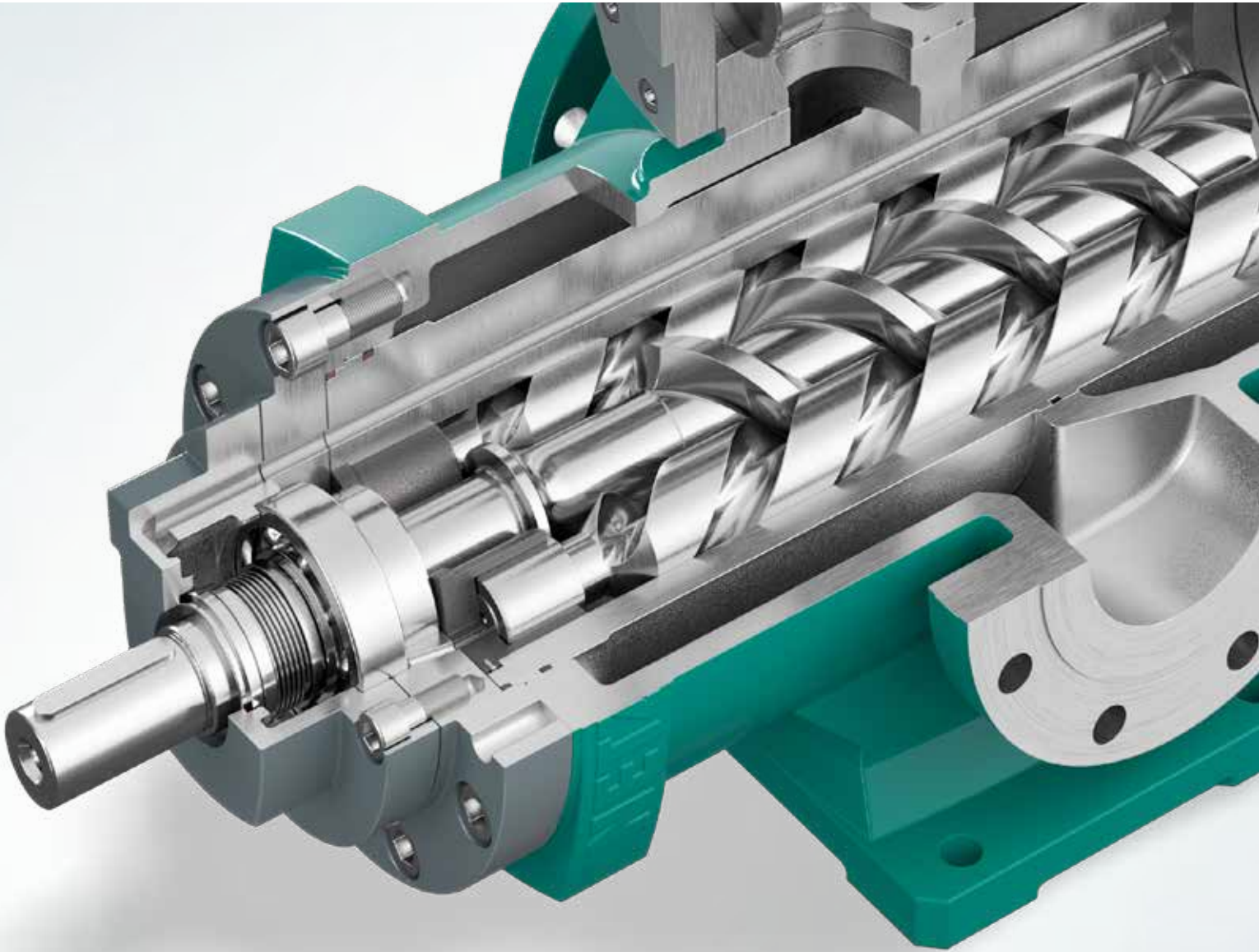

NOTOS® 3NS Multi Screw Pump

Ultimate design for lubrication, transferring and injection of lubricant fluids

Pump & Systems

For over four decades NETZSCH has been producing high quality NOTOS® Pumps for different industries.

High efficiency

NOTOS® 3NS Series pumps

Versatile, compact and efficient. The NOTOS® 3NS three-screw pumps have a modern design and patents that ensure a lower power consumption. The unique geometry of the screw and the state-of-the-art manufacturing process assures a significant reduction in power consumption.

Mount horizontally or vertically, 3NS pumps have a flow range of 2 to 1,760 gpm / 0.5 to 400 m³/h, reaching pressures up to 2,320 psi / 160 bar.

The 3NS line has models for viscous and low-lubricating products. The pump can work at low temperatures (-40 °F / -40 °C) as well as temperatures up to 572 °F / 300 °C. NOTOS® 3NS three-screw pumps are widely used in the oil and gas; marine; loading and unloading tanks, trucks and trains; and in the electric power generation industries, among others.

Application Examples

- Lube Oil
- Hydraulic Oil
- Crude Oil
- Diesel
- Fuel Oil
- Low Sulphur diesel

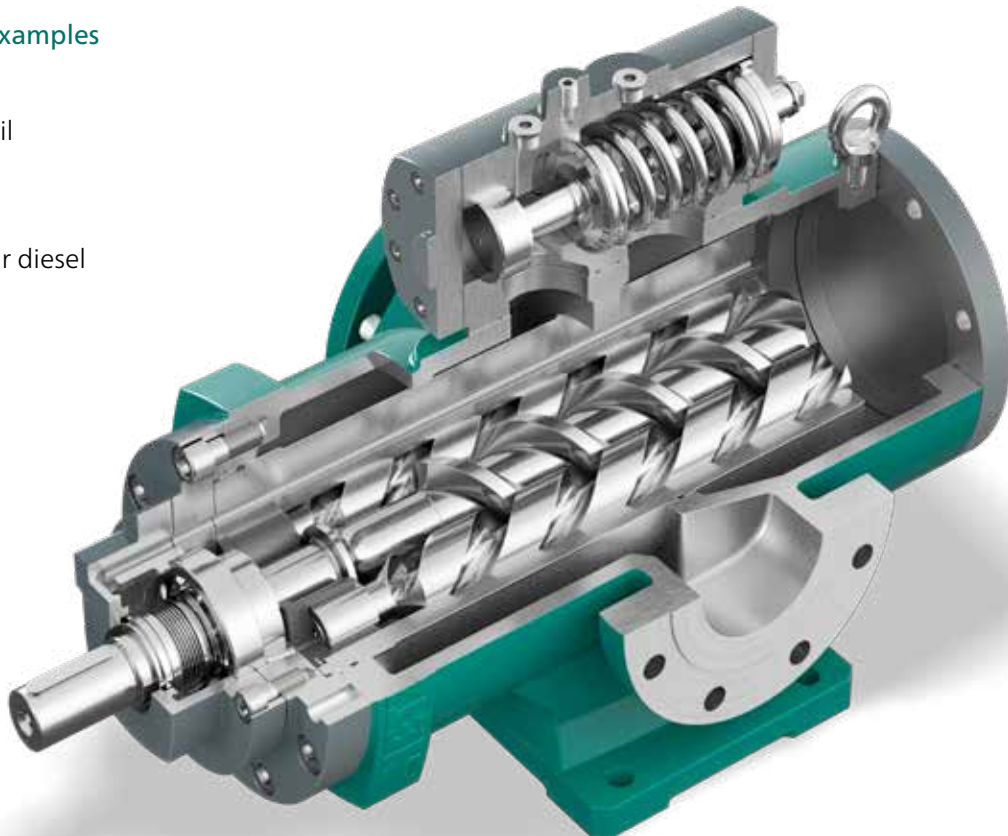

General characteristics

The NOTOS® 3NS pump consists of a drive screw that transfers torque to other two driven screws which are lubricated by the pumped fluid.

Advantages

- Low noise
- High efficiency
- Long service life
- Low vibration
- Low shear
- Excellent suction capacity
- In accordance with API 676, as an option
- Easy service
- Compact and silent
- Optional cartridge design

High Efficiency Unique Design

Because of its state-of-the-art machining process, the 3NS pump tolerances are designed to achieve the maximum flow per revolution.

Design features:

- Minimum tolerances
- Optimized screw profile
- More flow per revolution
- Low internal slip

Standards

- ATEX
- CE
- ISO 9001

High flow and pressure capacity

The 3NS pump can achieve higher flow rates and pressures.

- Flow rate up to 1,760 gpm / 400 m³/h
- Pressure up to 2,320 psi / 160 bar
- Viscosity from 1.5 to 15,000 cSt

Design

Considering the current design options, the 3NS meets many installation needs including installation in tight spaces.

- Housing (H)
- Semi-submersible (S)
- Lite (L)
- Mini (M)
- Vertical
- Horizontal

Wide range of seals

To ensure effective sealing, we offer many sealing options.

- Single and double mechanical seal
- Magnetic coupling
- Optional sealing plans suited for every application
- Cartridge options
- Balanced or unbalanced
- As per API 682

Additional features

- Optional heating or cooling jacket
- Optional removable pump cartridge
- Optional magnetic coupling
- Coatings suitable for every application

Industries of applications

The 3NS pump lines are widely used in pumping lube oil into large machinery - such as turbines or compressors - or fuel oil/diesel into combustion engines for in-land or offshore power generation.

- Oil and Gas
- Marine
- LACT Units
- Lubrication
- Defense
- Tank Storage Design

Mounting

Wide range of design options to meet customer needs.

- Horizontal foot over a rigid base
- Horizontal or vertical flange with no need for alignment
- Vertical pedestal for tight space applications
- Tank mounted

Internal Coatings

The 3NS pump employs coating specially selected for each application.

- Metal coating for abrasive applications
- High-hardness surface treatment for screws
- Polymer coating for low viscosity applications

Operation and Design

Principles of the NOTOS® 3NS Pumps

The NETZSCH 3NS Pump can be separated into three hydraulic parts: suction area, discharge area, and fluid return area. This pump operates with a drive screw engaged with two driven screws, transferring torque from one screw to the others. The screws are enclosed inside the pump housing and are made of hardened ferrous material.

Inside the pump, the fluid fills the chamber volume between the drive screw and driven screws while navigating from the suction to the discharge ports. After lubricating the mechanical seal, the fluid goes through the return channel and into the suction area, this way, the mechanical seal is exposed only to the suction pressure.

1 Screw

Nitrided steel, carbon alloy or stainless steel. Excellent performance due to its high efficiency unique design. All screws are 3D measured during the manufacturing process to assure a perfect profile.

2 Housing

Different flange configurations such as: in-line, side-top or top-top. They can be manufactured from ductile cast iron or fabricated in carbon steel or stainless steel.

3 Bushings

Internal bushings are additional hydraulic bearings that provides protection against startup failures, improving hydraulic balancing.

4 Mechanical Seals

Under suction pressure regardless of the discharge pressure. Packing rings, simple and double seals, and magnetic coupling options.

5 Discharge

Patented discharge optimized to ensure lower speeds, lowest turbulence and higher energy efficiency.

6 Suction and Discharge Nozzles

The 3NS pump has in-line options, offset or custom directions and sizes depending on the customer's needs. SAE, ANSI, DIN, JAS standards are available.

7 Bearing

The 3NS pump bearing has a typical service life above 100,000 hours, which is possible due to its hydraulic the axial and radial loads over the bearing. It can be lubricated by pumped product or protected and lubricated by special greases.

8 Load reducers

The bushings and the design of the screws ensure the lubrication, and the mechanical seal is exposed to the suction pressure, not discharge, increasing its service life and reducing maintenance needs.



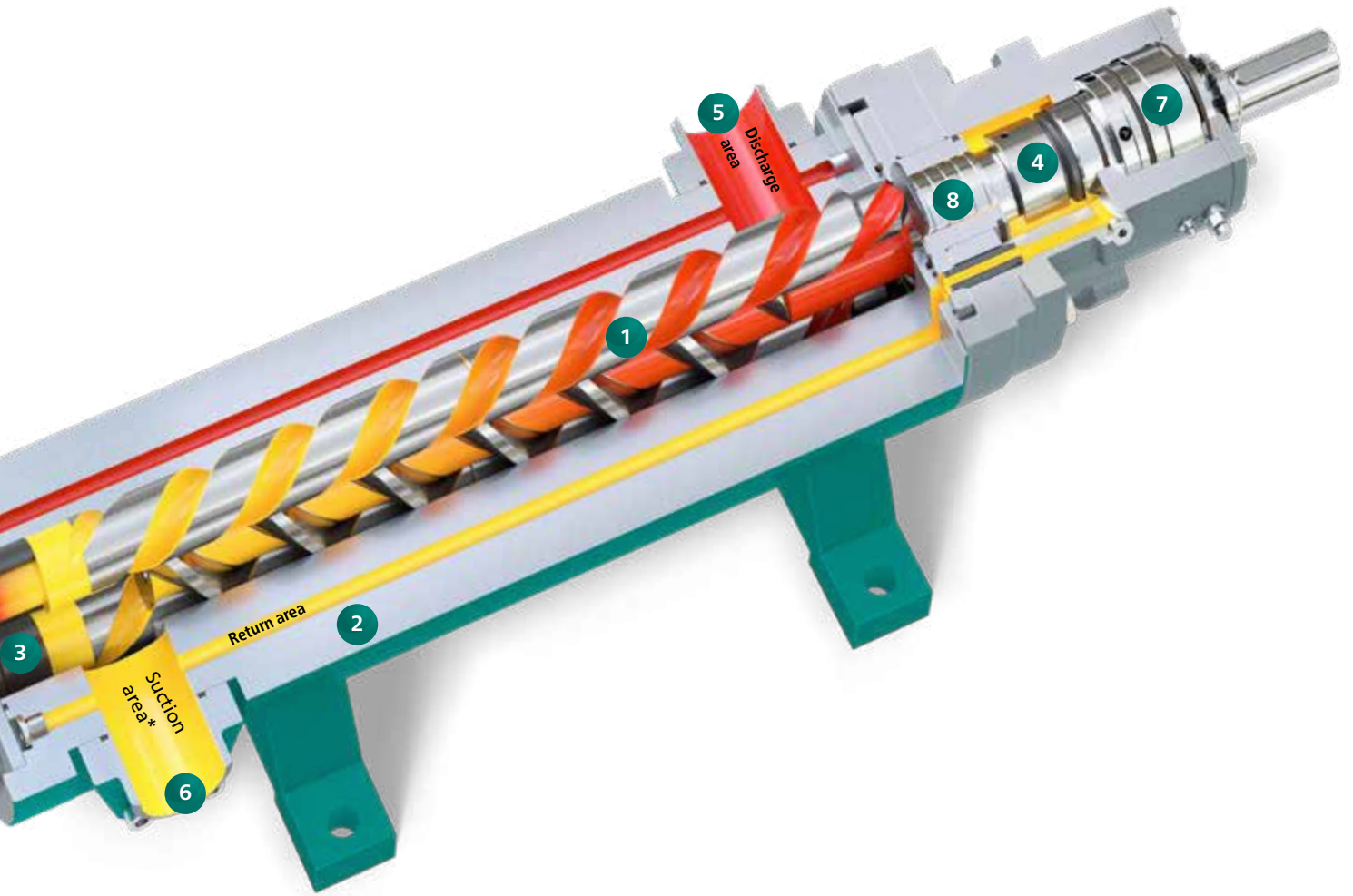

The design of each screw is suitable for a range of pressure, depending on the application. Longer screws can achieve higher pressures.



NOTOS® 3NS Design Options

Multiple versions for specific applications

The NOTOS® 3NS Multi Screw Pump family is available in the following series: 3NS-16/ 3NS-25 / 3NS-80 / 3NS-120 models. The versions of these pumps can be H - housing, L - lite, M - mini, and S - semi-submersible.

3NS / 16 Series

H-Housing Version

Assembly: Flange or pedestal (Vertical)

Capacity

Flow rates up to 145 gpm / 40 m³/h and pressures up to 232 psi / 16 bar.

Design

With ductile cast iron housing, standard "E" (external) bearing and mechanical seal, the internal relief valve is adjustable up to 145 to 230 psi / 10 to 16 bar and its nozzles are fixed and in line. Optional "I" (internal) bearing with magnetic coupling.

Application

Lube oil, diesel, low sulphur diesel, fuel oil, polyol, isocionate



3NS / 25 Series

M-Mini Version

Assembly: Flange (horizontal or vertical)

Capacity

Flow rates up to 37 gpm / 10 m³/h and pressures up to 363 psi / 25 bar.

Design

Extremely compact, the 3NS Mini series has nozzles built into the housing according to the SAE J518 drilling standard. The design has an internal relief valve for various applications and can be installed horizontally with a self-aligning drive stool or vertically in a tank.

Application

Lubrication, Seal plans, OEM skids



3NS / 25 or 3NS / 80 or 3NS / 160 Series

L-Lite Version

Assembly: Flange or foot

Capacity

3NS / 25 or 80, flow rates up to 295 gpm / 80 m³/h and pressures up to 1160 psi / 80 bar.

3NS / 160, flow rates up to 145 gpm / 40 m³/h and pressures up to 1,740 psi / 120 bar.

Design

With a liner-free ductile iron cast housing, it has top/top or axial/top flanges in SAE J518 material and internal bearing. Can be used vertically or horizontally. Easy to maintain.

Application

Lube oil, fuel oil, diesel, glycox, hydraulic



3NS / 25 or 3NS / 80 Series

H-Housing, S-Semi-submersible Version

Assembly: Foot, flange, pedestal or Tank for Semi-submersible pump

Capacity

3NS / 25, flow rates up to 1,465 gpm / 400 m³/h and pressures up to 363 psi / 25 bar.

3NS / 80, flow rates up to 735 gpm / 200 m³/h and pressures up to 1,160 psi / 80 bar.

Design

With ductile cast iron housing and removable liner, unaligned side/side flanges, with suction/discharge from the left to the right. It has an internal or external bearing. The pedestal version saves space. Optional bolt-on pressure relief valve.

Application

Lube oil, fuel oil, crude oil, asphalt, bitumen, fuels, hydrocarbons



3NS / 120 Series

H-Housing or L-Lite Version

Assembly: Foot

Capacity

Flow rates up to 145 gpm / 40 m³/h and pressures up to 1,740 psi / 120 bar.

Design

Specifically designed for low viscosities and high pressure, with fabricated pump housing and external bearing.

Various housing design options.

Application

LACT units, midstream pipelines



NOTOS® 3NS-S

Semi-submersible

The NOTOS® 3NS-S (Semi-submersible) pump is designed for in-tank installation. It includes a reservoir to allow the pump to start operating with fluid consequently preventing dry run. The design prevents operational errors and valve failure.

Additionally, the 3NS-S design includes a removable cartridge that allows easy inspection and service. The entire pump housing and the immersion stays in place during maintenance while the cartridge is the only part that needs to be removed. No pipework has to be disconnected.

1 Prime connection, required just for the first start-up

2 Reservoir that ensures the pump is always lubricated, preventing failures

3 Immersion tube, designed according to the tank, with an optional, built-in stainless steel filter

4 Fabricated housing, adaptable to the customer's installation

5 Removable cartridge for easy service

6 High-hardness nitrided screws for pressures up to 1,160 psi / 80 bar

Application

- Lubrication for turbines in hydropower plants
- Governor system regulation
- Lubrication systems that require constant flow and reliability

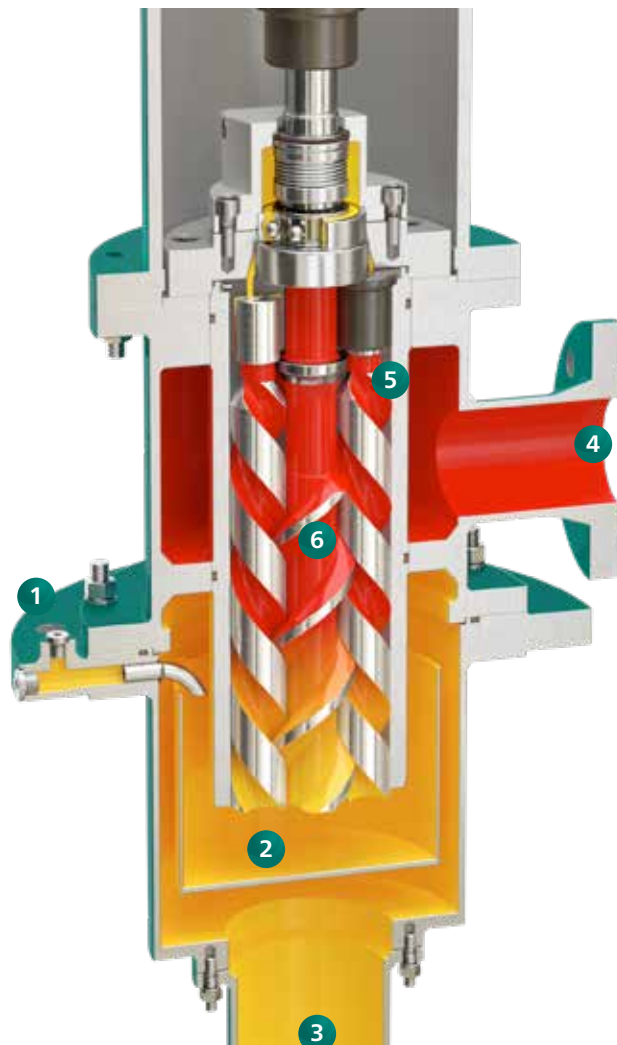

Zero Leakage

Compact, self-aligned and zero leakage, the 3NS pump, with magnetic coupling, is designed for pumping liquids that can not leak, such as isocyanate or other harmful fluids. The special design with magnetic coupling provides an internal recirculation through the axle, ensuring the lubrication of movable parts and cooling. The magnetic coupling is available in different material options such as stainless steel or ceramic designs specific to each application.

- 1 Compact housing, available in flange or pedestal versions
- 2 Highly hardened nitrided screws for pressures up to 232 psi / 16 bar
- 3 Ball bearing lubricated by the pumped product—no external lubrication needed
- 4 Magnetic coupling lubricated and cooled by the pumped fluid
- 5 Built-in relief valve, adjustable to different pressures depending on the application
- 6 Vertically or horizontally mounted

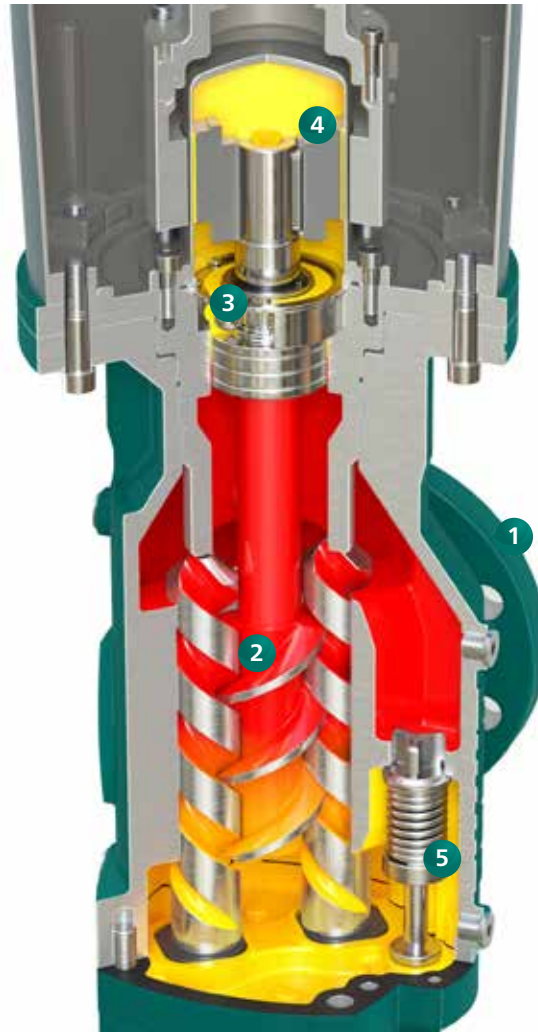

Examples of application

Burner Feed

- NOTOS® Pump: 3NS_80L5E
- Fluid: Diesel
- Flow rate: 35.6 gpm / 9.7 m³/h
- Pressure: 290 psi / 20 bar
- Temperature: 122 °F/ 50 °C
- Viscosity: 3 cSt



High Pressure Pipeline cleaning

- NOTOS® Pump: 3NS96_160H7I
- Fluid: Light crude
- Flow rate: 102.6 gpm / 28 m³/h
- Pressure: 870 psi to 1,450 psi / 60 to 100 bar
- Temperature: 104 to 176 °F / 40 to 80 °C
- Viscosity: 6 cSt



Compressor Lubrication

- Design: API 676
- Flow rate: 95.3 gpm / 26 m³/h
- Pressure: 145 psi / 10 bar
- Fluid: Lube oil ISO VG 46
- Viscosity: 46 cSt



Lubrication System

- NOTOS® Pump: 3NS_25M2E
- Fluid: Lubricant oil
- Flow rate: 1.8 to 61 / 9 gpm / 0.5 to 16.9 m³/h
- Pressure: 44 up to 75 psi / 3 up to 5 bar
- Temperature: 77 to 140° F / 25 to 60 °C
- Viscosity: 6 to 7000 cSt



Fuel Oil Injection System

- NOTOS® Pump: 3NS_80H8E
- Fluid: Fuel oil / Diesel
- Flow rate: 77.7 to 163 gpm / 21.2 to 44.5 m³/h
- Pressure: 39 up to 363 psi / 2.7 up to 25 bar
- Temperature: 86 to 140 °F / 30 to 60 °C
- Viscosity: 1.5 to 622 cSt



Crude Oil Transfer from Storage tanks

- NOTOS® Pump: 3NS_80H11E
- Fluid: Crude API 45
- Flow rate: 373.9 gpm / 102 m³/h
- Pressure: 174 psi / 12 bar
- Temperature: 89.6 °F / 32 °C
- Viscosity: 2.5 cSt



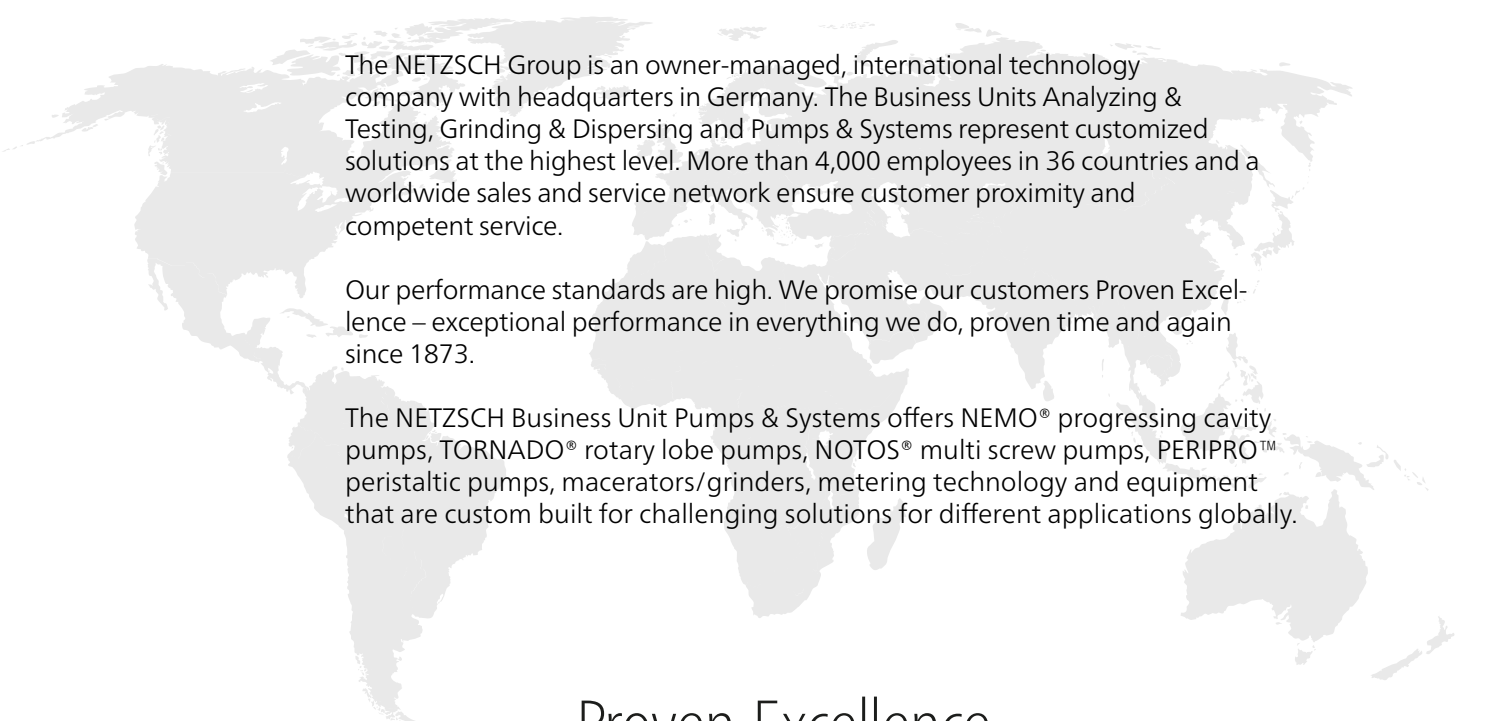

The NETZSCH Group is an owner-managed, international technology company with headquarters in Germany. The Business Units Analyzing & Testing, Grinding & Dispersing and Pumps & Systems represent customized solutions at the highest level. More than 4,000 employees in 36 countries and a worldwide sales and service network ensure customer proximity and competent service.

Our performance standards are high. We promise our customers Proven Excellence – exceptional performance in everything we do, proven time and again since 1873.

The NETZSCH Business Unit Pumps & Systems offers NEMO® progressing cavity pumps, TORNADO® rotary lobe pumps, NOTOS® multi screw pumps, PERIPRO™ peristaltic pumps, macerators/grinders, metering technology and equipment that are custom built for challenging solutions for different applications globally.

Proven Excellence.■

NETZSCH Pumps USA
119 Pickering Way
EXTON, PA 19341-1393
USA
Tel.: +1 610 363 8010
Fax: +1 610 363 0971
npa@netzsch.com

NETZSCH Pumps USA
1511 FM 1960 Road
Houston, TX 77073
Tel.: +1 346-445-2400
npa@netzsch.com

NETZSCH Canada, Incorporated
500 Welham Road
Barrie, ON L4N 8Z7
Canada
Tel.: 705 797 8426
Fax: 705 797 8427
ntc@netzsch.com

NETZSCH®

pumps-systems.netzsch.com