

TORNADO® Rotary Lobe Pump T1 Series MB-F

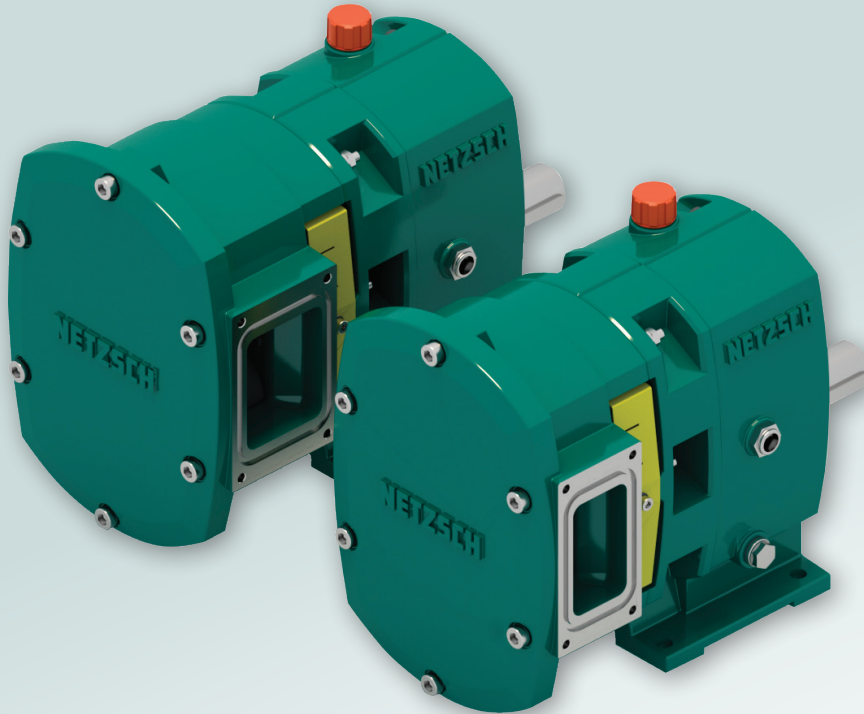

The new generation of the TORNADO® T1 Series MB-F Lobe Pump is available in two different sizes developed to the highest standards of quality, technology and efficiency.

Performance

- Capacity up to 140 gpm / 32 m³/h
- Maximum pressure 145 psi / 10 bar
- Temperature up to 195°F / 90°C
- Viscosity from 1 to 50,000 cP

Product Advantages

- Maximum operational reliability: NETZSCH GSS¹ Technology
- Full Service-in-Place (FSIP®) maintenance
- Low installation and maintenance cost
- Compact construction
- Installation flexibility
- High suction capacity up to 28 feet / 8.5 meters
- Reversible flow
- Low operating cost

¹ Gearbox Security System - a physical air separation between the mechanical seal and the lip seal off the timing gearbox

Wide application range

Suitable for a wide range of applications, but particularly for liquids that:

- Contain solids
- Have a wide range of viscosities
- Are sensitive to shear, such as thixotropic, dilatant, pseudo-plastic and others
- Are fibrous and/or abrasive
- Whether lubricating or non-lubricating liquids

TORNADO® T1 Series MB-F



- 1 Pump cover
- 2 Wear plates
- 3 Cover seal
- 4 Lobular rotor
- 5 Mechanical seal
- 6 Pump Body
- 7 Gearbox

Adapter types



Straight

Goose neck

90° knee

Type meas	A	B	C	D	E	F	G	H	I	J	K	L	M	N	O	P	Q	R	S	T	U	Y	W	X	Z	
MB-1F																										
in	15.63	11.61	8.34	3.78	4.92	4.55	6.10	3.82	3.94	2.36	.157	1.38	1.5	.39	5.31	6.46	.51	.47	5.9	3.54	4.96	5.59	1.98	2.44	3.07	
mm	397	295	212	96.12	125	115.5	155	97	100	60	4	35	38	10	135	164	13	12	150	90	126	142	50.2	62	78	
MB-2F																										
in	16.42	11.61	8.34	4.18	4.92	4.55	6.10	3.82	3.94	2.36	.157	1.38	1.5	.39	5.31	6.46	.51	.47	5.9	3.54	4.96	5.59	2.76	3.15	3.86	
mm	417	295	212	106.2	125	115.5	155	97	100	60	4	35	38	10	135	164	13	12	150	90	126	142	70.2	80	98	

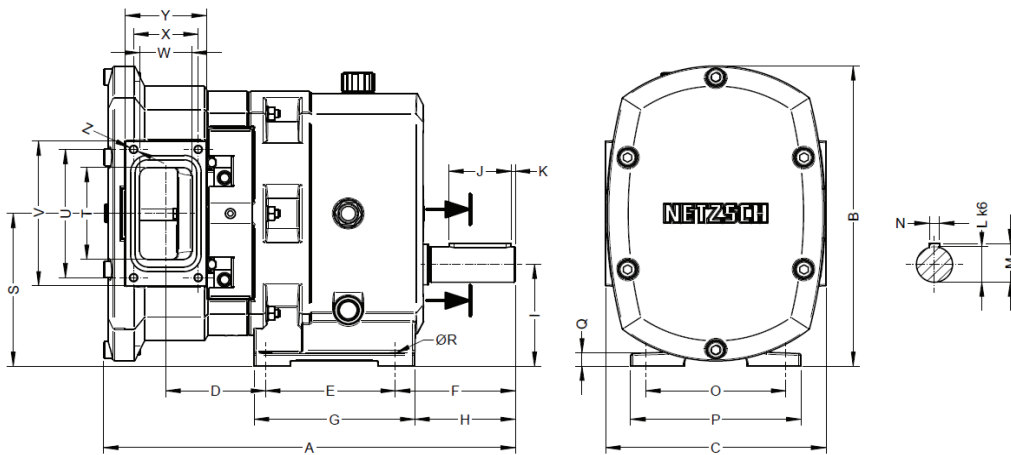

pumps-systems.netzsch.com

NETZSCH Pumps USA · 119 Pickering Way · Exton, PA 19341
 Phone: 610 363-8010 · Fax: 610-363-0971 · npa@netzsch.com

NETZSCH Pumps USA · 1511 FM 1960 Road · Houston, TX 77073
 Phone: 346 445-2400 · npa@netzsch.com

NETZSCH Canada Incorporated · 500 Welham Road · Barrie, ON L4 8Z7
 Phone: 705 797-8426 · Fax: 705-797-8427 · ntc@netzsch.com