

NETZSCH

Proven Excellence.

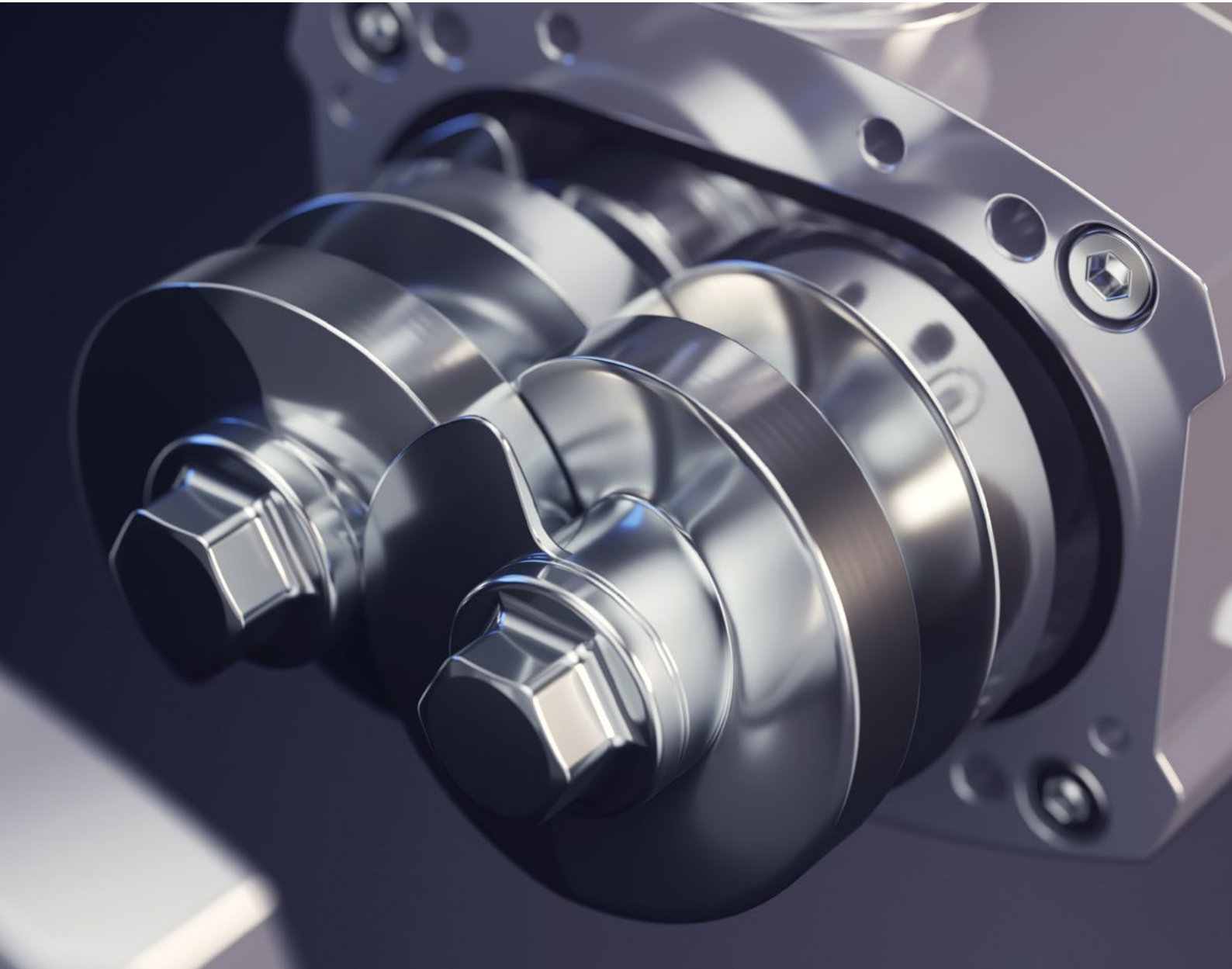

NOTOS[®] Hygienic Twin Screw Pump

NOTOS[®] 2NSH – High Efficiency and Maximum Performance
for Hygienic Applications

Pumps & Systems

NOTOS® 2NSH

HYGIENIC TWIN SCREW PUMP

The benefit to the customer

Keeping its commitment to developing innovative and efficient solutions for the most demanding industries, NETZSCH presents to the market the NOTOS® Hygienic 2NSH Twin Screw Pump. Designed to optimize the transfer at high working pressures (up to 25 bar or 360 psi) of media with higher viscosity, such as chocolate, fruit yogurt, juices, and pumping them while keeping the integrity and natural properties, without any quality loss. This pump is a practical solution that adds more efficiency and technology to the process.

The pump is made of AISI 316L stainless steel and polished according to international standards, making it easy to clean (CIP) and to sterilize (SIP). As there is no contact between the rotating parts, the pump speed can be increased. Therefore cleaning can be carried out without the need for an auxiliary system.

INCREASED PERFORMANCE

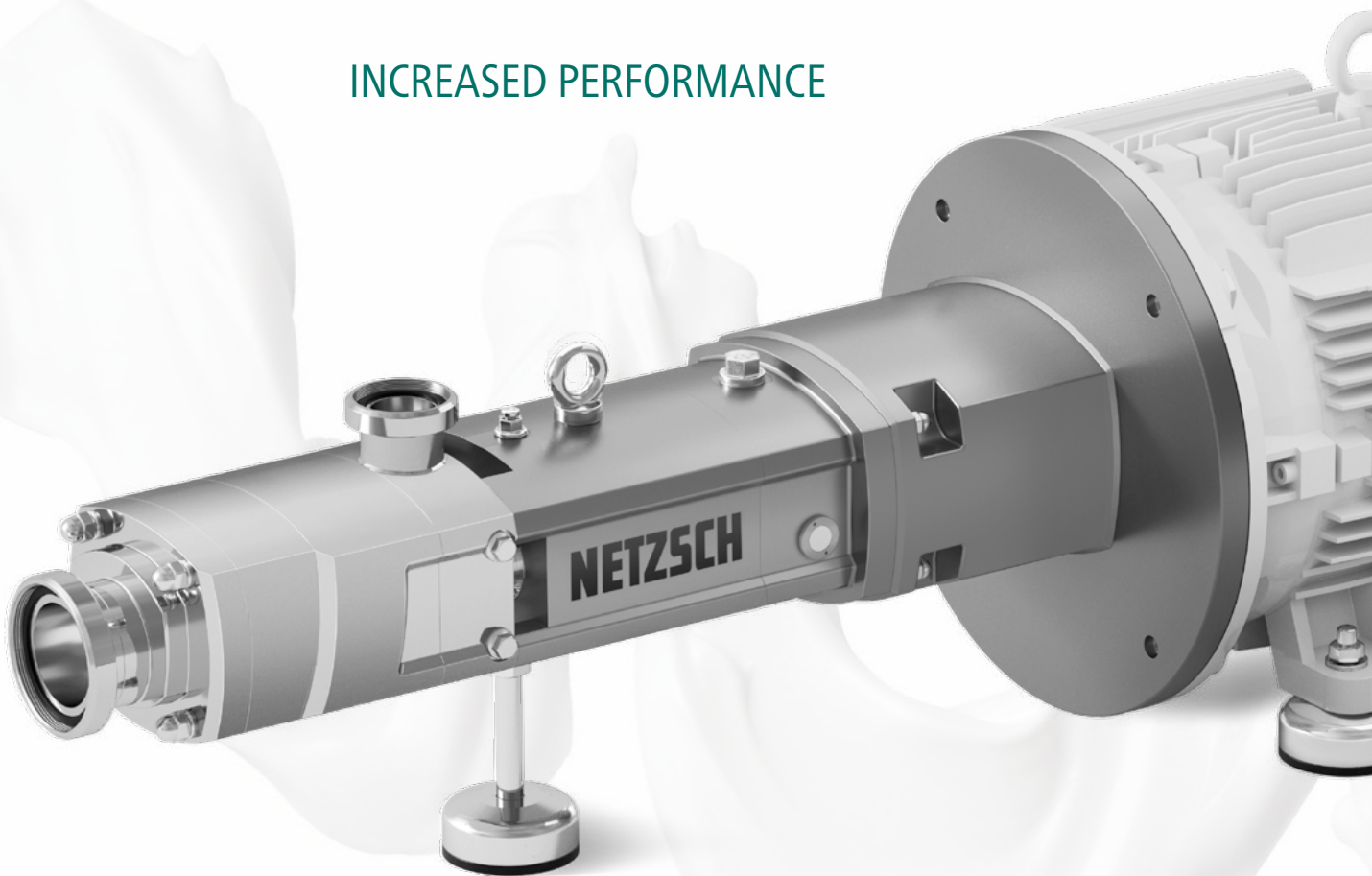

MAXIMUM PRODUCTIVITY

INNOVATIVE CONCEPT

General characteristics

NOTOS® 2NSH meets the high requirements of food, beverage, chemical, pharmaceutical and cosmetic industries:

- Metal parts made of stainless steel
- High suction capability (low NPSHr)
- No contact between the rotating parts
- Reversible flow
- Low pulsation
- No dead spaces
- Smooth feeding of the pumped media

Large capacity and pressure range

The pump covers a wide capacity range and is therefore highly flexible in use.

- Flow rate up to 230 m³/h (1012 gpm)
- Pressure up to 25 bar (360 psi)

Compact design

Small space requirements due to their compact design, having two options for mounting: with foot or flange.

Broad range of applications

- Food industry: dairy products, delicacies, ketchup, sauces, confectionery and baby food
- Beverage industry: fruit juices, syrups, concentrates, breweries
- Cosmetic and pharmaceutical industry: creams, active substances, ingredients
- Chemical industry: adhesives, solvents, paints, varnishes and plastics

Your benefits

- Versatile use eliminating the need for a CIP pump
- Easy maintenance: simple assembly/disassembly
- Flexibility: the same equipment can be used for pumping fluids with low or high temperature/viscosity
- Seals with food-grade certification

Wide range of media

Due to the operation principle and the design of this positive displacement pump, media with the following properties can be conveyed:

- Low to high viscosity
- With/without solids
- Shear sensitive and shear stable



NOTOS® 2NSH

Several applications with many advantages

With a robust, compact body and efficient design, the NOTOS® 2NSH Hygienic Twin Screw Pump is ideal for industries that prioritize high quality, maximum productivity, and excellence in the process: a reliable, customized solution for each customer.

NOTOS® 2NSH Hygienic Twin Screw Pump – Operating Parameters

Parameters	Models			
	2NSH - L1	2NSH - L2	2NSH - L3	2NSH - L4
Maximum flow	Up to 25 m ³ /h	Up to 52 m ³ /h	Up to 109 m ³ /h	Up to 175 m ³ /h
Maximum rotation speed	Up to 3.600 rpm	Up to 3.300 rpm	Up to 2.800 rpm	Up to 2.400 rpm
Maximum peak pressure	Maximum 25 bar	Maximum 25 bar	Maximum 25 bar	Maximum 25 bar
Viscosity	Up to 1.000.000 cP	Up to 1.000.000 cP	Up to 1.000.000 cP	Up to 1.000.000 cP
Pumped fluid temperature	Up to 165 °C	Up to 165 °C	Up to 165 °C	Up to 165 °C
Discharge nozzle dimension	From 1.1/2" to 2"	From 2" to 3"	From 2.1/2" to 4"	From 3" to 4"
Suction nozzle dimension	From 1.1/2" to 2.1/2"	From 2" to 4"	From 3" to 4"	From 3" to 4"
Wetted component material	AISI 316L (standard)	AISI 316L (standard)	AISI 316L (standard)	AISI 316L (standard)
Maximum solid particle size	13 mm	16 mm	20 mm	30 mm

3-A authorized equipment
EHEDG certified equipment



2NSH - L5
Up to 230 m ³ /h
Up to 2.000 rpm
Maximum 25 bar
Up to 1.000.000 cP
Up to 165 °C
From 4" to 6"
From 4" to 6"
AISI 316L (standard)
36 mm

The NOTOS® 2NSH is a hygienic (screw) pump series consisting of five basic sizes, each with four models with different performance levels (flow rate/pressure). There are therefore 20 different types in total. They cover numerous flow rate ranges and fulfil the requirements of almost all segments of many industries.

Maximum flow rate of each pump

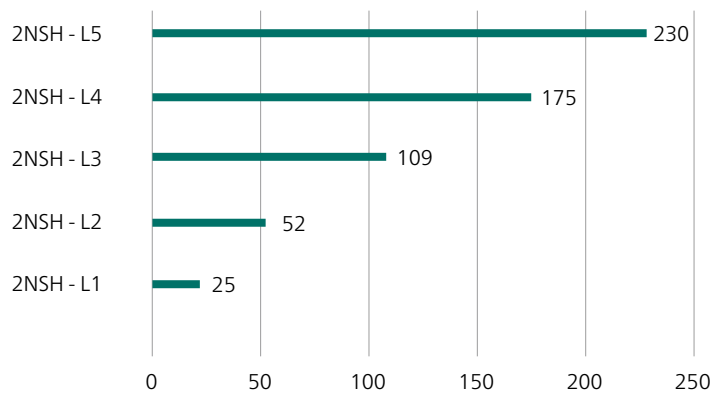

Perfection down to the last detail

for outstanding results in your production

The pump shows superior performance and excellent results in day-to-day production because every pump feature is perfectly worked out. The NOTOS® 2NSH Hygienic Twin Screw Pump is an efficient combination of excellence and quality that results in a unique solution to the market with a significantly compact design. Smooth pumping, low pulsation, easy maintenance, and ease of use in the process are advantages that support you in your daily operations.

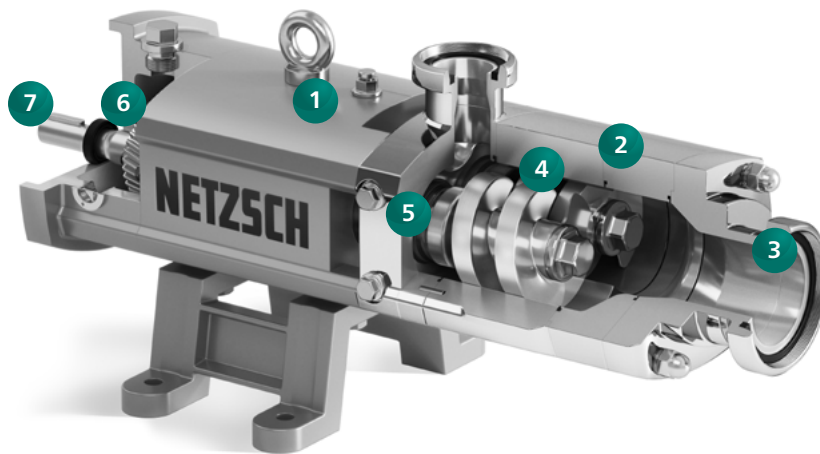

1 Bearings housing

Bearings designed for high load capacity with housing in stainless steel allowing external cleaning of the pump.

Various sanitary connection options available such as DIN, TC, SMS, RJT, and others.

5 Shaft sealing

Available with single or double seals, both with modular cartridge design and interchangeable from one to another. Connections for flushing or quench are provided.

2 Pump housing

Pump housing with a unique design for FSIP® – Full Service in Place, allowing the easy and quick pump disassembly, without having to disconnect it from the piping. Available in foot or self-aligned flange design. FDA-approved sealing, without dead spaces.

4 Screws

Stainless steel screws with high efficiency profile, allowing higher flow rates with low fluid shear. Multiple pitch options available, all balanced and with high suction capability. Easy replacement of the screws without disassembly of the bearings. Screws with the same diameter are changeable just by changing the pitch.

6 Synchronization gears

Helical gears provide smooth torque transmission between the screws and ensure the contactless operation of the pumping elements.

3 Flanges

Internally polished flanges as per hygienic standards to ensure complete pump cleaning [Ra < 0.8 µm].

7 Shafts

Stainless steel shafts designed for high torque, with the option to rotate in both directions.

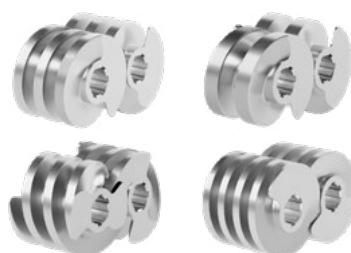

FSIP® concept for simplified maintenance

The NETZSCH Research & Development Department implemented FSIP® as a design concept in many products. It simplifies maintenance and the life of service staff. Thus it is possible to fully disassemble and assemble the screws and the mechanical seal without removing the pump from the processing line. As a result of this, the servicing downtimes are significantly reduced. FSIP® is an intelligent technological solution that brings even more comfort and reliability to your processes.

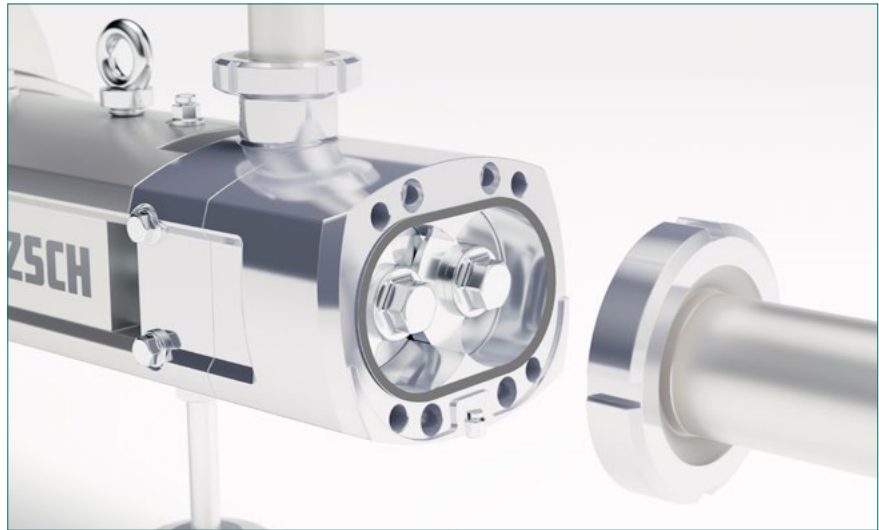

Simplify your CIP cleaning process with NOTOS® 2NSH

Reduce your costs with NOTOS®

In a conventional CIP cleaning-process usually an additional CIP pump is necessary to ensure the cleanliness of the system. With the 2NSH, there is no need for an extra pump because it also operates as a CIP pump during the cleaning process. By-pass valves and additional pipework are not necessary anymore.

How is it possible?

Its constructive form allows to reach the speed necessary for CIP cleaning. With a flow velocity of at least 1,5 m/s, it is possible for the cleaning liquid to ensure efficient cleaning of the pump, pipes, connections and accessories.

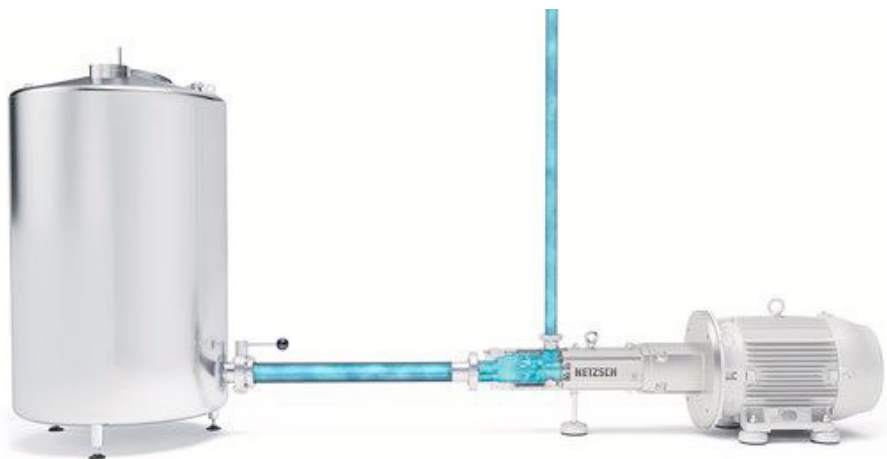

CIP/SIP temperature
Up to 140 °C

Conventional Design with unique advantages

The NOTOS® 2NSH Hygienic Twin Screw Pumps are also available with a conventional, round pump housing. This compact design offers different options and advantages.

The NOTOS® 2NSH conventional pump housing is more compact than the FSIP® model. It is shorter, which facilitates the installation in places with less space. Its surface is polished according to international standards, avoiding the accumulation of residues and simplify the cleaning.

General characteristics

- Compact design
- Reduced length
- Robust construction
- Heating or cooling jacket (optional)

Different pump models

- With foot and flange design
- With funnel for highly viscous fluids
- Special executions possible

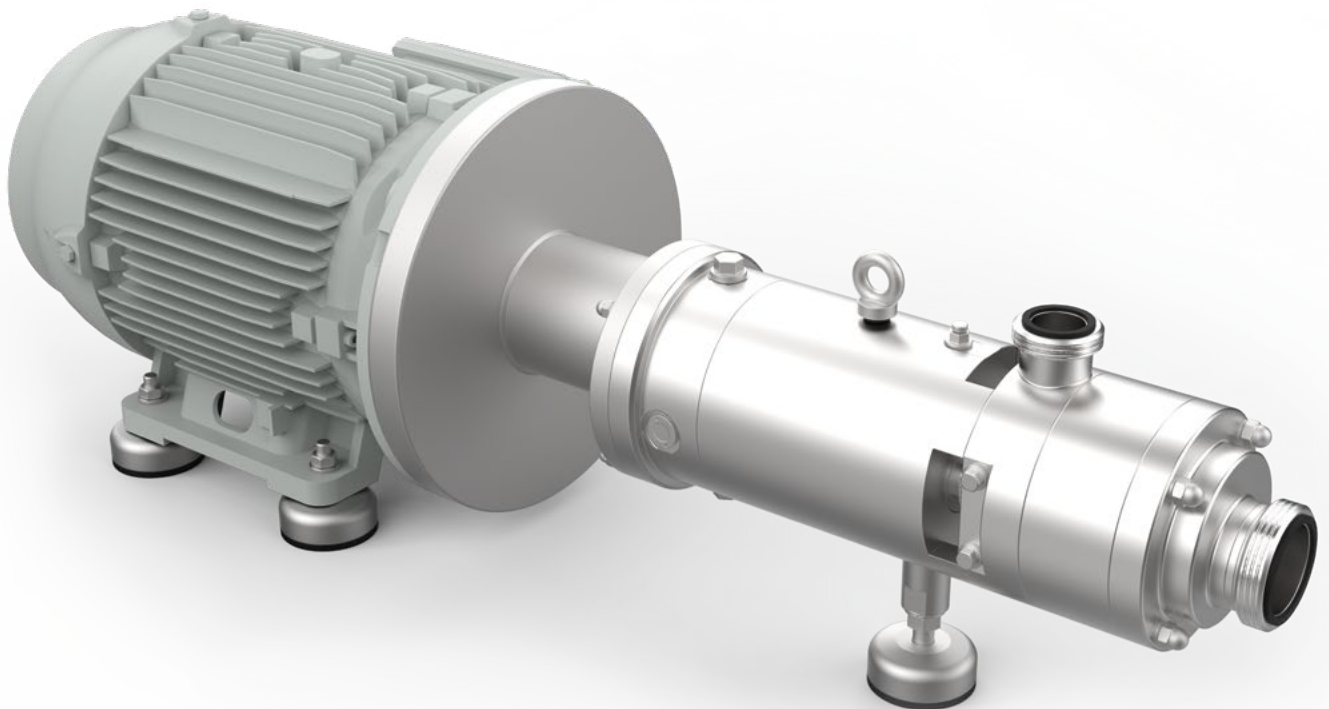



Adding a jacket for heating or cooling allows temperature control of the fluid

The conventional version of the NOTOS® 2NSH Hygienic Twin Screw Pump can be equipped with a heating or cooling jacket. The jacket is installed around the entire housing in which the screws are located. An external, independent circuit heats or cools the jacket. This pump is perfect for applications where the pumped fluid tends to harden or requires temperature control to guarantee its quality.

General characteristics

- Heating or cooling jacket
- Heating/cooling medium: water 0–130°C
- 3 bar pressure (45 psi)

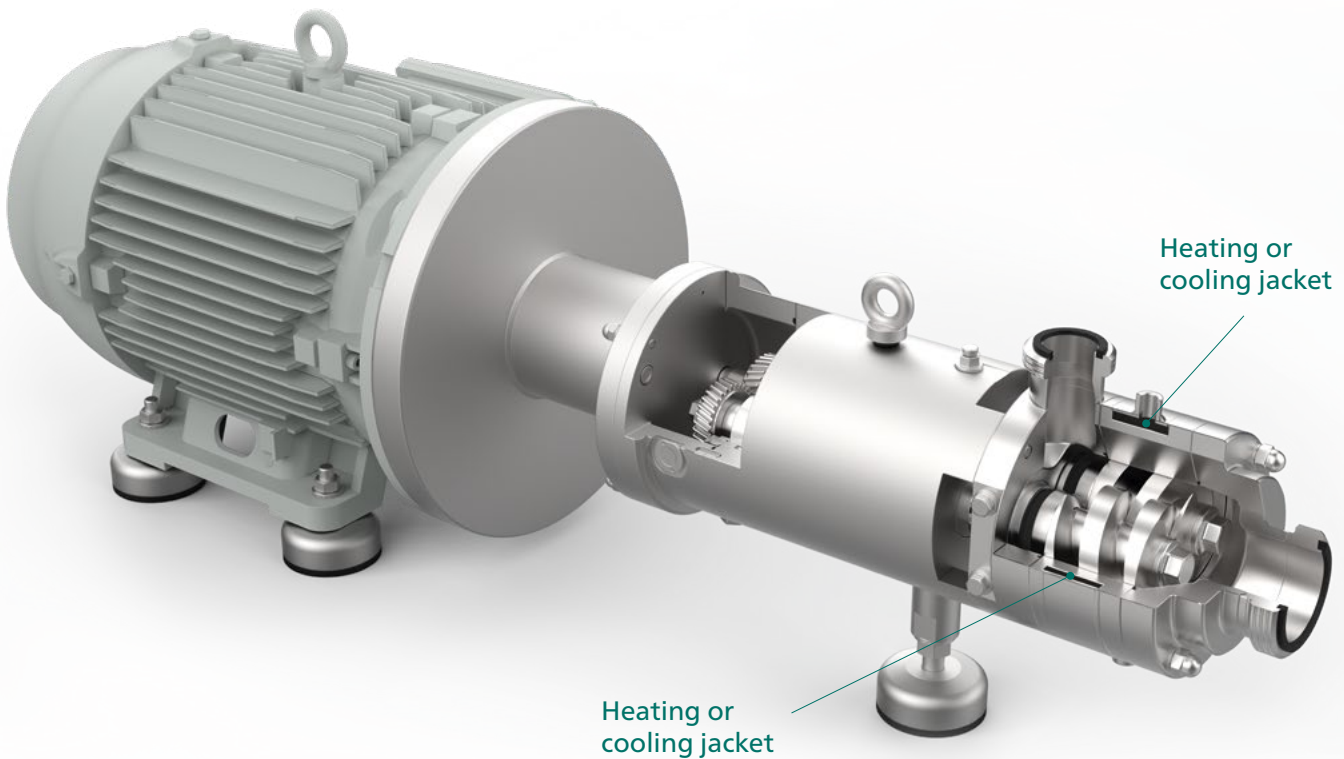

BARREL EMPTYING SYSTEM

with NOTOS® 2NSH pump

NETZSCH Barrel Emptying Units pump their way through your products, reaching the bottom of the barrel or container in the food, chemical, and pharmaceutical industry with the absolute minimum waste of product – resulting in less than 1 % residual product in the barrel. The heart of the barrel emptying unit is a NOTOS® 2NSH pump. With positive displacement it creates a low pulsation flow to convey the product without damage. The products are only exposed to friction loss through the discharge piping. The NETZSCH single slide rail system raises and lowers the follower plate safely while providing a simple and easy structure to clean.

Construction features

Barrel emptying NBE 200 + NOTOS® 2NSH pump. Hygienic connections available, such as DIN, TC, SMS, RJT, and others.

Your benefits

- Smooth and steady pumping
- Low pulsation
- Low shear rate
- Products that contain solids in suspension
- Flow independent of temperature or viscosity
- Almost complete emptying, residual product less than 1 %

NBE characteristics

- Continuous or intermittent emptying
- No pressure or flow interruption
- Low-pressure conditions in the entire system
- Suitable for conical barrels
- Adjustable discharge capacity
- Possible to dose directly from the barrel
- Flow in direct proportion to pump speed
- Equipped with VSD for easy adjustment
- Simple, single-rail design

Applications

- Low to high viscosity
- Non-Newtonian and pastes
- Shear sensitive media
- Pump can handle media up to 500.000 cp



APPLICATION EXAMPLES

Juice and beverage industry

- Pump: NOTOS® 2NSH340/16L3E
- Media: Orange juice concentrate
- Flow rate: 25 m³/h
- Pressure: 8 bar
- Temperature: 5 °C
- Viscosity: 900 cP

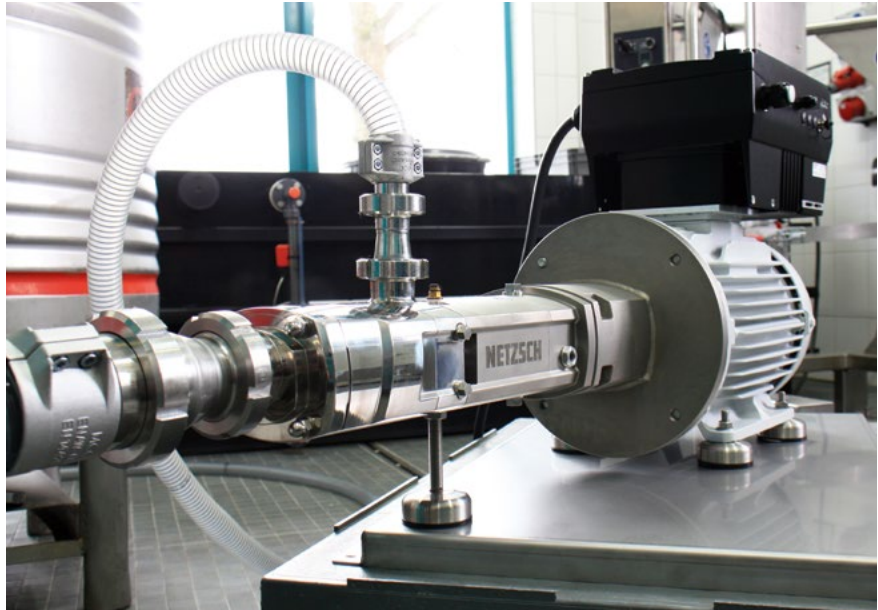

Chemical and pharmaceutical industry

- Pump: NOTOS® 2NSH55/16L1E
- Media: Shampoo
- Flow rate: 5 m³/h
- Pressure: 6 bar
- Temperature: 25 °C
- Viscosity: 9000 cP



The owner-managed NETZSCH Group is a leading global technology company specializing in mechanical, plant and instrument engineering.

Under the management of Erich NETZSCH B.V. & Co. Holding KG, the company consists of the three business units Analyzing & Testing, Grinding & Dispersing and Pumps & Systems, which are geared towards specific industries and products. A worldwide sales and service network has guaranteed customer proximity and competent service since 1873.

The NETZSCH Business Unit Pumps & Systems offers NEMO® progressing cavity pumps, TORNADO® rotary lobe pumps, NOTOS® multi screw pumps, PERIPRO® peristaltic pumps, macerators/grinders, dosing technology and equipment that are custom built for challenging solutions for different applications globally.

Proven Excellence.

NETZSCH Pumpen & Systeme GmbH
Geretsrieder Straße 1
84478 Waldkraiburg, Germany
Tel.: +49 8638 630
info.nps@netzsch.com
www.pumps-systems.netzsch.com



NETZSCH®

www.netzsch.com