

N.Mac[®] Inline

TWIN SHAFT GRINDER FOR INLINE INSTALLATION

The N.Mac[®] twin-shaft grinder is capable of fragmenting large and solid objects in a liquid media. It is the ideal equipment to suit different applications such as waste water treatment, substrates or food and fruit scraps for biogas plants. The inline housing allows installation in piping systems to protect downstream equipment, such as pumps. It is also available in a channel housing design.

Features

- Twin shaft technology with internal rotation for size reduction of solids
- Energy efficient motors, from 3 -5 HP / 2.2 - 4 kW
- Low speed cutters with high torque
- Cartridge style cutters make for easy maintenance and load dispersion
- Optional control unit with reverse direction of rotation in case of blockages
- Five different cutting teeth for various applications
- Dual recessed and self-collapsing lifing tabs for simple pull-out for servicing

Your benefits

- Unique shock absorption system
- Mechanical seals with quench
- Optional cleaning combs for fibrous materials
- Cutting devices in cartridge system
- Patented bearing and mechanical seal cartridges
US #9,422,985 B2
- 3 Year Warranty

Main Applications

- Waste water treatment plants
- Biogas plants
- Agriculture
- Slaughterhouses and recycling plants
- Food waste
- Crushing of foreign matter, such as plastic, bags and bottles, shoes, textiles, aluminum cans, tin scrap and lids



N.Mac[®] 50I Horizontal design



N.Mac[®] 50I



N.Mac[®] 150I



N.Mac[®] 350I

Cutter cartridges

Specific cutter geometries for each type of solids facilitate the particle reduction process. To reach the required particle size the different cutters with 3 to 11 teeth may be combined accordingly.

Wear resistance

The cutters are thermally hardened to increase resistance and maintain sharpness assuring reliable grinding of the toughest solids.

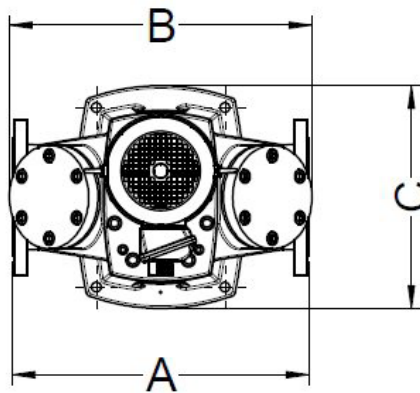
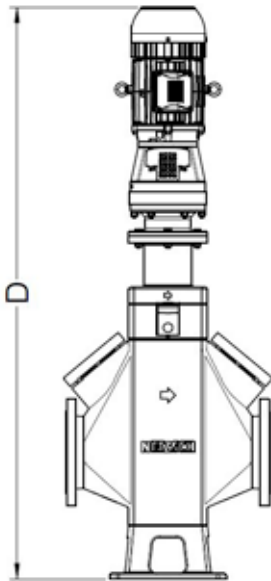

Controller

Controller is available with automatic starting direction to ensure even wear of the knives and shear plate. The controller also can detect jammed media and run through a sequence or auto reversal three times to free the unit before shutting down and setting off alarm.

Flow rates and dimensions

Sizes	Flow rate (gpm / m ³ /h)	Pressure drop (psi / bar)	Maximum pressure (psi / bar)	Approximate weight (lbs / kg)	Flanges (ANSI/DIN)	Dimensions (inches / mm)			
						A flange to flange	B max width	C	D
N.Mac® 50I Horizontal	220 / 50	.725 / 0.05	90 / 6.0	485 / 220	4" / 100	13.3 / 340	13.3 / 340	42.7 / 1,085	15.1 / 384
N.Mac® 50I	220 / 50	.725 / 0.05	90 / 6.0	485 / 220	4" / 100	13.3 / 340	13.7 / 350	17.5 / 445	45.5 / 1,155
N.Mac® 150I	660 / 150	1.74 / 0.12	90 / 6.0	793 / 360	6" / 150	21.4 / 545	21.8 / 555	16.1 / 410	60.0 / 1,525
N.Mac® 350I	1,541 / 350	1.16 / 0.08	90 / 6.0	1,719 / 780	8" / 250	32.6 / 830	32.6 / 830	16.7 / 425	70.0 / 1,780

NETZSCH®

pumps-system.netzsch.com

NETZSCH Pumps USA · 119 Pickering Way · Exton, PA 19341
Tel.: 610 363-8010 · Fax: 610 363-0971 · npa@netzsch.com

NETZSCH Pumps USA · 1511 FM 1960 Road · Houston, TX 77073
Tel.: 346 445-2400 · npa@netzsch.com

NETZSCH Canada Incorporated · 500 Welham Road · Barrie, ON L4 8Z7
Tel.: 705 797-8426 · Fax: 705 797-8427 · ntc@netzsch.com