

NETZSCH

Proven Excellence.



Food & Pharmaceutical

Technology, Markets and Applications

Pumps & Systems



You've got the application, WE'VE GOT THE SOLUTION

Within the Pumps & Systems business unit, the Food & Pharmaceutical sector holds a crucial position worldwide for uncompromising hygiene and the highest process requirements in all areas of production.

When it comes to demanding conveying processes, **NEMO® progressing cavity pumps** are often the first choice - because they are extremely robust: They convey liquids with low and high viscosities at flow rates of up to 140 m³/h and have proven themselves to be excellent even for abrasive media and media containing solids.

The **TORNADO® rotary lobe pumps** are the solid allrounders among the displacement pumps, also in the hygienic version: They are robust, offer very high performance at moderate speeds and are compact.

The technology of the **NOTOS® screw pumps**, on the other hand, is particularly smart. They have the advantage that the conveying elements operate contactless - very high speeds and wide flow ranges are possible but the pump is still low-wear and guarantees the highest product safety.

PERIPRO peristaltic pumps are typically suitable for media that are difficult to seal in the cosmetic and food sectors. This pump does not require a mechanical seal.

Our Product Range

FOR YOUR HYGIENIC PROCESS

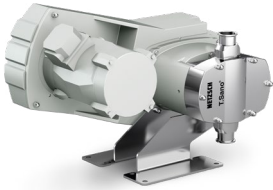

TORNADO® Rotary Lobe Pump

- Flow rates up to 120 m³/h
- Pressures up to 12 bar
- Temperature: 150 °C



NEMO® Progressing Cavity Pump

- Flow rates up to 140 m³/h
- Pressures up to 24 bar
- Temperature: 150 °C

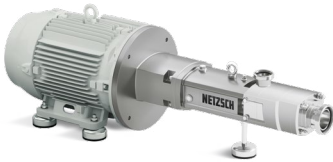

NOTOS® Multi Screw Pump

- Flow rates up to 200 m³/h
- Pressures up to 16 bar
- Temperature: 130 °C



PERIPRO Peristaltic Pump

- Flow rates up to 13,000 l/h
- Pressures up to 10 bar
- Temperature: 80 °C



NETZSCH Barrel Emptying Systems

- Flow rates up to 12 m³/h.
- For emptying standard containers 20 l bis 200 l
- Residue without liner <1 %

Click here and go directly to our business field food & pharmaceutical:

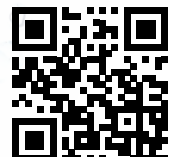

TORNADO® Rotary Lobe Pumps

POWERFUL, ROBUST AND COMPACT

The lubricant oil-free design makes the hygienic T.Sano® ideal for food and pharmaceutical media.

NETZSCH TORNADO® self-priming, valveless, positive displacement pumps can be optimally customised to meet specific process and application requirements. They can be used for almost any media on intermittent, continuous or dosing applications.

CIP-/SIP-Process

This pump can also be used as a cleaning pump. All materials are suitable for CIP and SIP processes.

Certificates

The T.Sano Smooth is certified according to

- 3A
- EHEDG certified (depending on media wetted elastomer and mechanical seal materials, flange sizes), with a vertical nozzle position

Capacities and pressures

- Flow rates up to 120 m³/h
- Pressures up to 12 bar

Suitable for the following media:

- Shear sensitive
- With or without solids
- Medium up to high viscosity (up to 100,000 mPas)
- Thixotropic and dilatant
- Lubricating and non lubricating

Advantages

- Gentle product handling
- Reversible flow direction
- Flow rate in proportion to speed
- Safe to run dry
- Easy maintenance of the conveying elements and shaft seal without removing the pump from the pipeline



Characteristics and typical components of the powerful rotary lobe pump

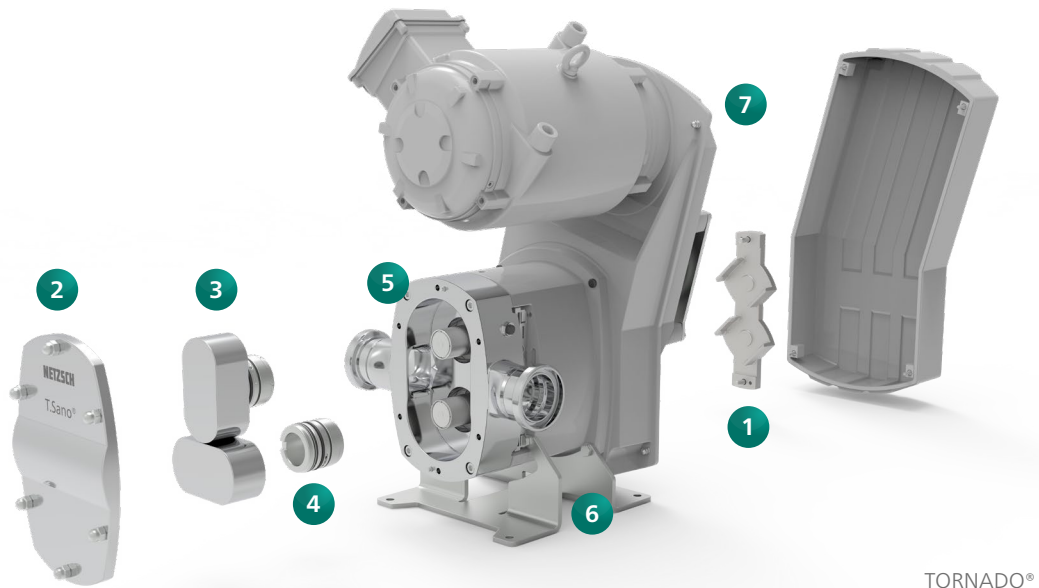

TORNADO® T.Sano Smooth

1 Rotor setting device

Using the setting device, the lobes are adjusted radially and axially.

2 Front cover

As an option, the pump cover can be heated.

3 Rotor

The stainless steel lobes are fixed outside the product area. Due to this, the front surface of the lobes is flat and prevents any dead space.

4 Seal

The cartridge design is available in single- and double-acting versions. The seal is positioned specifically to avoid dead space, and the rotating seal faces are within the medium flow path.

5 Rotor case

The suction housing is available with two options for connections: flanged or threaded. The interior of the housing has no dead space. The heatable pump housing is a standard feature of the T.Sano® Smooth model.

6 Bearing housing

The bearing housing is constructed to the BSS* System. The bearing block is spatially separated from the pump housing. The ball bearings are lubricated for life.

7 Tooth belt drive

Synchronisation and drive via maintenance-free tooth belt drive, which runs completely oil-free.

*BSS - Bearing Security System

Click here for the 3D model:



NEMO® Progressing Cavity Pumps

FOR HYGIENIC AND ASEPTIC APPLICATIONS

The advantage of the NEMO® progressing cavity pump lies in its flexibility. It is suitable for many different media. Even abrasive media hardly lead to wear. The flow rate is determined by the speed and can therefore be precisely controlled. However, the NEMO® mainly scores with its continuous, low-pulsation conveyance – a plus for particularly sensitive fluids.

Chunky goods such as yoghurt with pieces of fruit are also treated gently. Solids are continuously displaced further in the pumping chambers that are formed between rotor and stator, without excessive pressure or friction occurring. Media with solids up to a diameter of about 5 cm can be pumped depending on the pump size.

For food manufacturers, this means that even ready meals such as tomato sauce with pasta or other ingredients can be transported with progressing cavity pumps. Product safety can be guaranteed.

Capacities and pressures:

- Flow rates up to 140 m³/h
- Pressures up to 24 bar

Suitable for the following media:

- Shear-sensitive
- Low to high viscosity
- Lubricating and non-lubricating
- With or without solids
- Dilatant or thixotropic
- Abrasive
- Adhesive

Certificates and guidelines:

- USA 3-A Sanitary Standards
- GOST-R (Certificate of Conformity for Russia)
- Materials are according to FDA (Food and Drug Administration)
- Regulation (EC) No. 1935/2004 (EU regulations food contact materials)

Advantages

- Flow rate independent of pressure and viscosity
- Product acceptance under vacuum conditions up to almost absolute vacuum



The design: That is why the pump conveys particularly gently

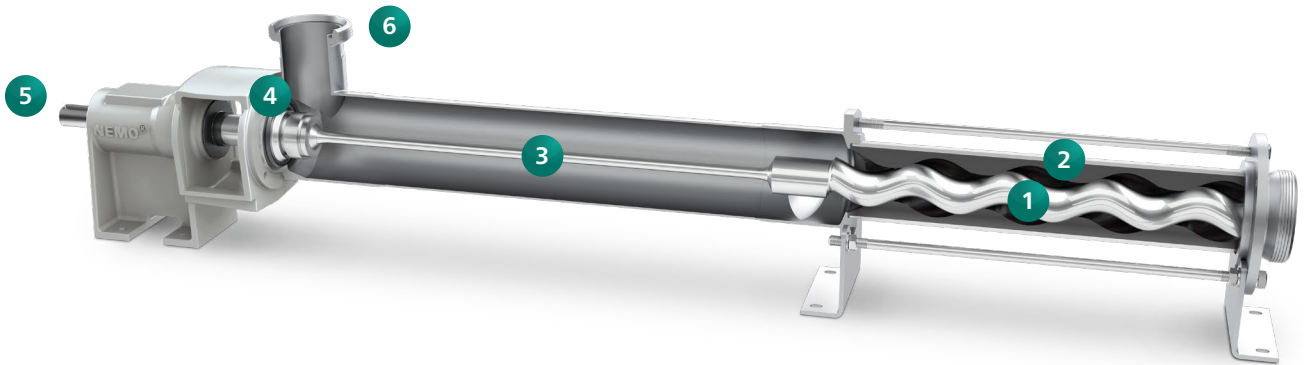

NEMO ®SH Hygienic Plus

1 Rotor

Made of stainless steel, in different geometries.

2 Stator

For changing product temperatures a patented stator with reduced elastomer wall thickness is available. In addition, a thermal stator protector (STP-2 or STP-D) for overheating and dry running protection may be used.

3 Drive train

Drive and connection shaft with coupling rod or two hygienic joints for drive transmission to the rotor.

4 Sealing housing

Various shaft sealings are available.

5 Drive

The design with a bearing bracket and free shaft end enable the universal use of all drive types. In the block design, drives are offered with specific flange and shaft dimensions.

6 Pump housing

Flow-optimized pump housing due to tangential inlet connection, also free of dead space.

Rotation Without Joint

THE EASY TO CLEAN FLEXIBLE ROD

To meet the high hygiene requirements, a flexible rod, rather than open joints or joints filled with oil, connects the drive to the shaft. This is heat-shrunk with the rotor and connection point so that the transition is hermetically sealed. Because there is no friction between components at the connection, there is hardly any wear on the flexible rod, and it needs no lubrication or seal, with low maintenance costs. Generally, polished stainless steel is used for medium contact surfaces, and a stator made of FDA-compliant elastomer is installed. A single-acting mechanical seal can be used as a shaft seal, optionally also a double-acting mechanical seal.

NEMO® SH Hygienic Plus Pump



Performance

Flow rates up to 140 m³/h at pressures up to 24 bar.

Features

The flexible rod is free of dead space and is wear- and maintenance-free so that it can be used even with highly sensitive and abrasive products. The design with bearing housing and drive shaft enable the universal use of all drive types.



The hygienic NEMO® progressing cavity pump is according to 3-A Sanitary Standards certified.



More information about NEMO® SH Hygienic Plus

Great value is also placed on small quantities: NEMO® BH Hygienic Mini Plus Pump

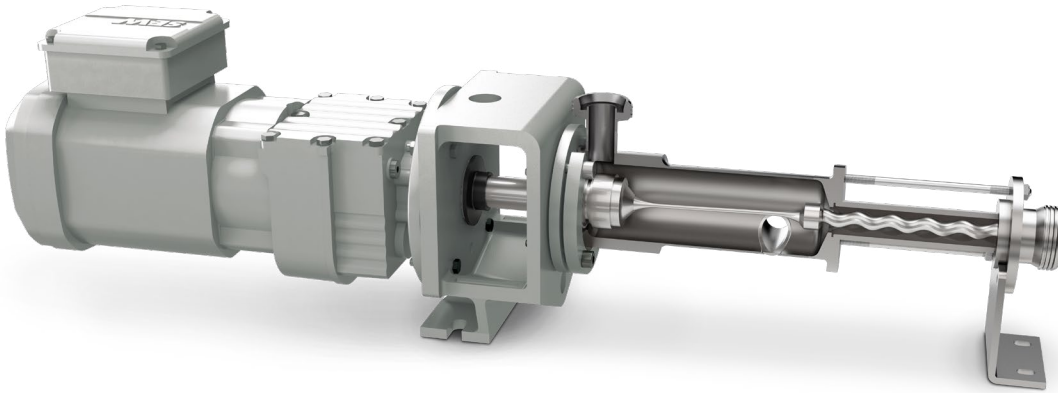

Performance

Flow rates from 0.1 up to 500 l/h at pressures up to 36 bar.

Click here for
the 3D model:



Features

The flexible rod is free of dead space and is wear- and maintenance-free so that it can be used even with highly sensitive and abrasive products. High dosing accuracy (deviation of < 1%). A compact design with a directly flanged drive reduces investment, operating and maintenance costs.

The CIP-/SIP process at the NEMO® pumps:

To achieve the flow rate of the cleaning liquids of at least 1.5 m/s required for the CIP cleaning process in the entire system, the NEMO® is fitted with additional flushing nozzles and a bypass line. Complete drainage of the NEMO® pump is ensured by tangential flushing nozzles.

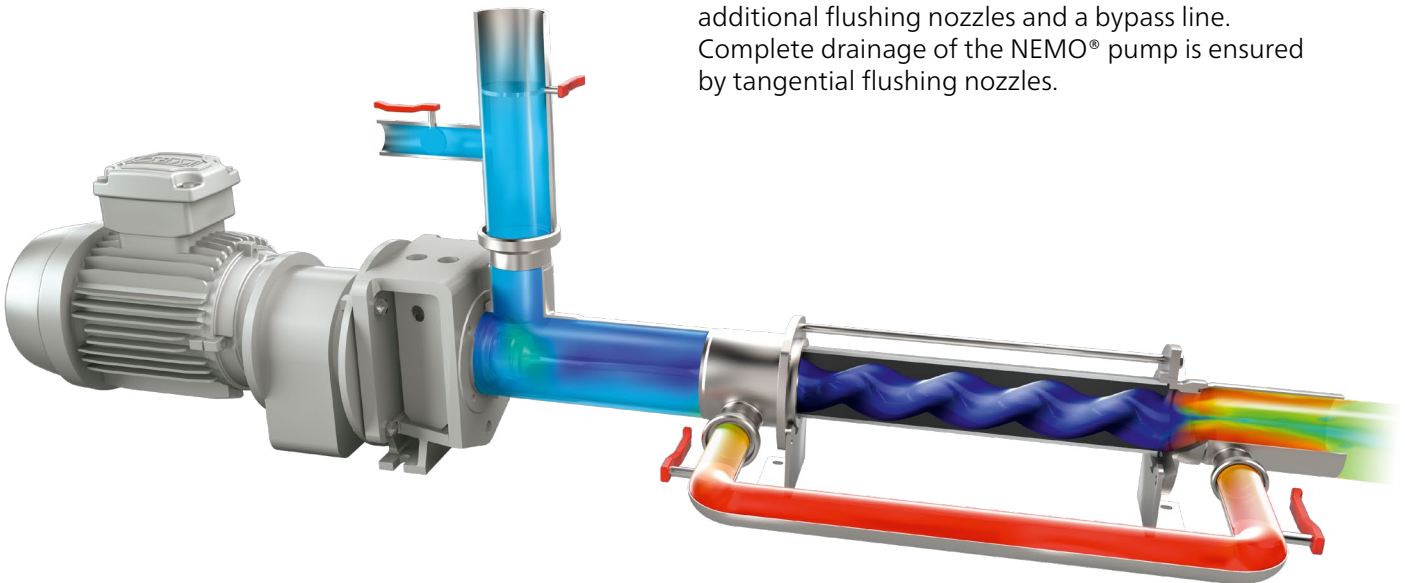

NEMO® BH Hygienic Pump

WITH HYGIENIC JOINT

NEMO® BH Hygienic Pump in standard version

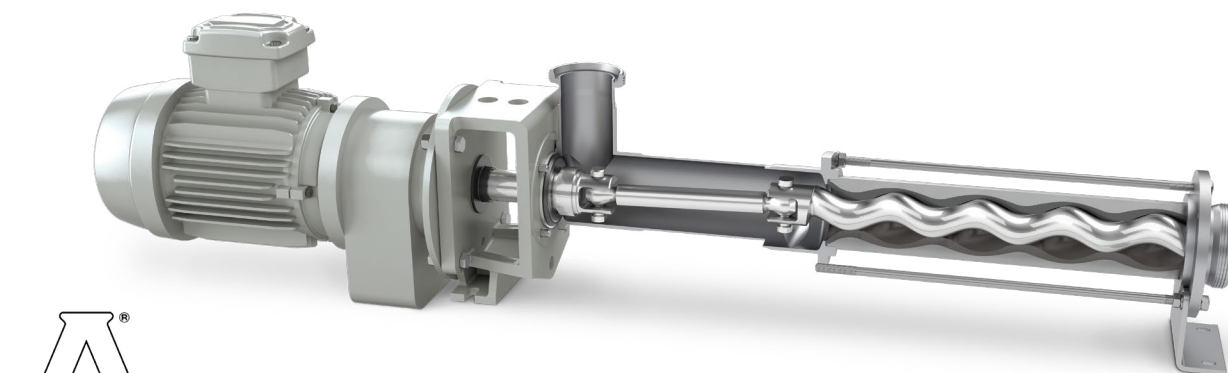

The NEMO® BH hygienic pump is designed with a streamlined, dead space-free housing. This prevents the media from settling. For this reason, all wetted surfaces are polished to prevent build-up of the medium and facilitate cleaning.

A unique feature of the NEMO® BH is the patented hygienic joint. It is an open, dead space-free joint for optimal cleaning.

Hygienic Joint

The specially developed joint is continuously lubricated by the medium itself. An additional seal or oil/grease lubrication of the joint is not required here, thus ensuring a high degree of product safety.

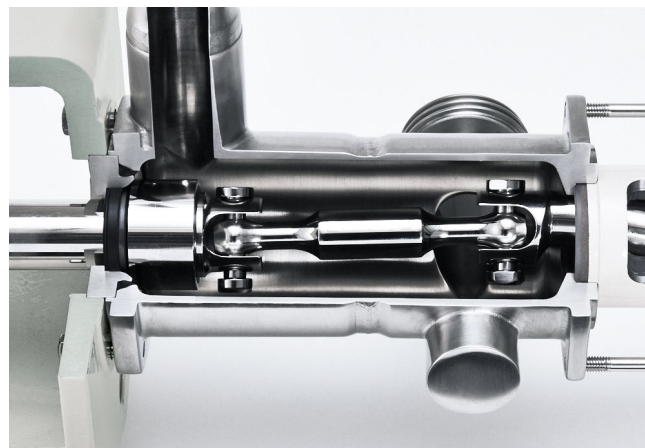

... and if it needs to be tempered: with an optional heating jacket

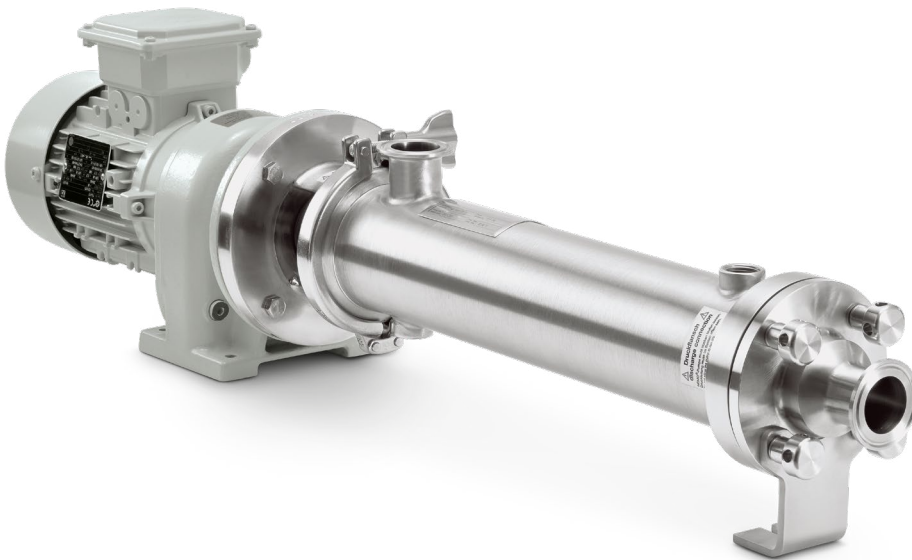

NEMO® BH Hygienic Pump, temperature-controlled

This pump has hygienic open pin joints, open housing seals, agitation elements on the coupling rod and a heating jacket over the entire stator and pump case area. All medium contact surfaces are polished. This prevents the medium from adhering and makes cleaning easier.

This pump is suitable for all hygienic applications, especially for viscous media that must be heated or cooled.

Performance

Flow rates up to 30 m³/h at pressures up to 12 bar.

Advantages

- Housing and stator can be efficiently heated or cooled
- Specially designed mechanical seals are arranged without dead space
- Product-friendly requirement
- Process-oriented cleaning

Click here for
the 3D model:

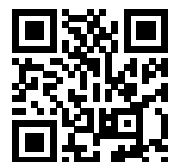

Combined Conveying and Cutting

THE NEMO® BO/SO HOPPER PUMP WITH CUTTING DEVICE

Two process steps in one mean more process reliability, saving of time and less machinery equipment

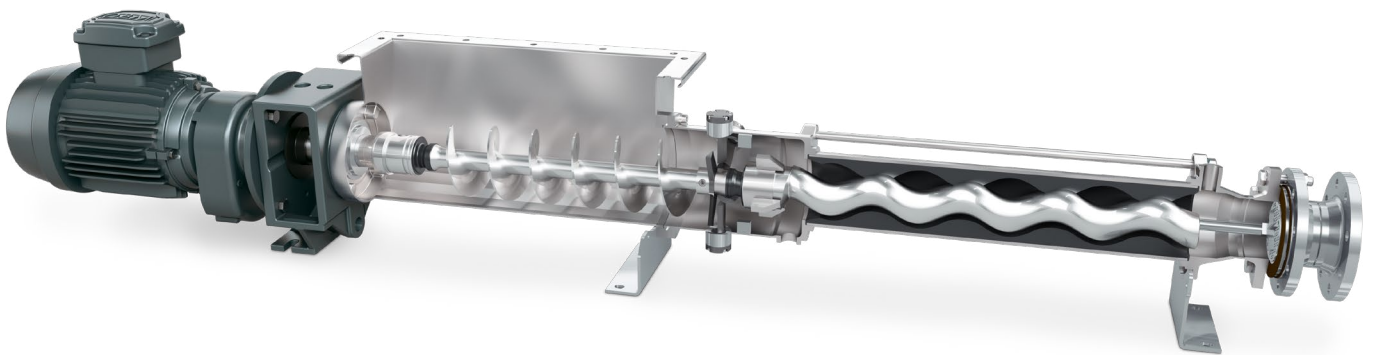

The NEMO® BO/SO progressing cavity pump with hopper and coupling rod with feeding screw and force-feed chamber is used in almost all branches of industry to provide continuous, pressure-stable, gentle and low-pulsation conveyance. This special version of a NEMO® BO/SO hopper pump with cutting device has been designed for applications in the food industry.

It guarantees optimum feed into the conveying elements and immediate cutting of larger fruits and vegetables passing the cutting unit placed inside the compression chamber. This unit consists of a rotating knife with three blades and a variable number of stationary knives adjustable to the size and consistency of the particles. Optionally the pump can be equipped with an additional cutting unit at the discharge flange of the pump.

With its perforated disc and rotating knife it allows for further fine definition of the particle size.

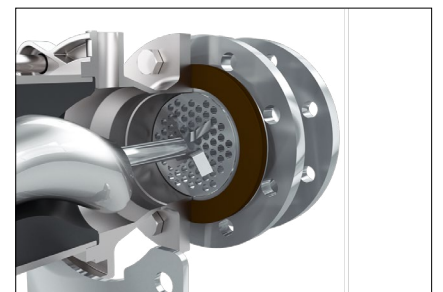

Click here for
the 3D model:

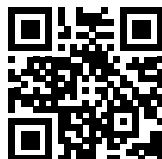

As any other NEMO® Progressing Cavity Pump also the BO/SO pump has the ability to dose the conveyed media in proportion to rotation speed. In block construction with a flanged drive, this pump is particularly compact and economical but it also available with bearing housing for a wider range of drives.

Features of the pump

- Hopper housing with rectangular inlet flange and feeding screw with force-feed chamber to provide optimal feed for your slowly flowing and pasty media into the conveying elements
- Continuous low-pulsation conveyance unaffected by fluctuations in pressure and viscosity
- Conveyance volume in proportion to rotation speed with high dosing precision over a broad rotational-speed range
- High-pressure capability without valves

Features of the cutting units

- Cutting unit in the compression chamber consists of a rotating knife with three blades and a variable number of stationary knives adjustable to the size and consistency of the particles
- Cutting unit at the discharge flange with perforated disc and rotating knife allowing for further fine definition of the particle size

Advantages

- Variable modular system for optimum conveyance and cutting
- Robust and compact construction
- Replacing additional machinery
- Constant flow
- Easy serviceability



NOTOS® Multi Screw Pump:

THE HYGIENIC TWIN SCREW PUMP FOR SENSITIVE MEDIA

Efficiency and high technological know-how for your hygienic process

This two-spindle pump was designed for hygienic applications in order to optimally pump media with higher viscosity at high working pressures of up to 16 bar. Chocolate, fruit juices or fruit yoghurt, for example, are pumped while maintaining their consistency and their natural properties, without any loss of quality. This pump is a practical solution that offers more efficiency and a high technological standard to the process.

Suitable for the following media:

- Low to high viscosity
- Media with/without solid content
- Shear-sensitive and shear-stable

Flow rates and pressure range:

- Flow rates up to 200 m³/h
- Pressures up to 16 bar

Accessories:

- Base plates
- Couplings
- Adjustable machine feet
- Supply facilities for flushed mechanical seals

Versions:

- The robust and compact conventional design, with optional heating or cooling jacket
- The FSIP version, which allows the spindles and mechanical seals to be dismantled in place, at the point of use. This reduces maintenance work and downtimes
- In foot and flange versions available

Certificates:

The 2NSH is certified according to

- 3A
- EHEDG

Advantages

- Can be used as a feed pump and CIP pump in one process
- Easy maintenance: quick assembly/disassembly
- Flexibility: The same equipment can be used for pumping fluids with low or high temperature/viscosity



The Design of the Elegant Notos®

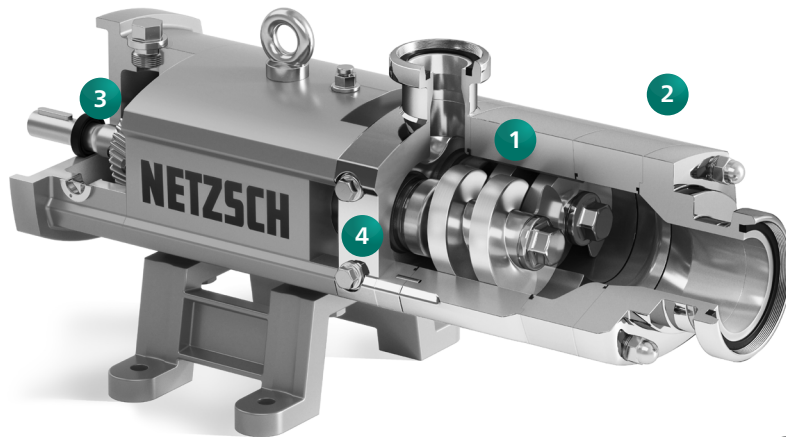

Click here for
the 3D model:



1 Screws

Stainless steel screws with a high-efficiency profile, allowing higher flow rates with low fluid shear. Multiple pitch options are available, all balanced and with high suction capability. Easy replacement of the screws without disassembly of the bearings. Interchangeable screws of the same size/length with variable pitches are available.

2 Housing

Pump housing with a unique design for FSIP® – Full Service in Place, allowing the easy and quick pump disassembly, without having to disconnect it from the piping. Available in the foot or selfaligned flange design. FDA-approved sealing, without dead spaces.

4 Shaft sealing

Various single-acting and double-acting interchangeable and service-friendly cartridge mechanical seals can be selected. They have a modular design and fit into the same housing. Connections for pressure flush and pressureless quench connections are available.

3 Synchronization gears

Helical gears provide smooth torque transmission between the screws and ensure the contactless operation of the pumping elements.

The PERIPRO PERISTALTIC PUMP

In the Food Version

NETZSCH PERIPRO peristaltic pumps do not contain mechanical seals, have an extremely high suction capacity and can run dry indefinitely. It is suitable for food and beverage as well as cosmetic products and complies with the latest specifications and regulations in this area. With this design, you can simplify your cleaning processes and increase efficiency.

The PERIPRO pump offers excellent energy savings, more hours of operation, longer hose life, and is easy to use.

Hygienic connections according to DIN 11851 or tri-clamp connections and the special design enable CIP cleaning through simple disassembly.

The extruded inner layer of the hose increases the life of this component, reducing the consumption of spare parts and maintenance.

At the same time, the efficiency of the cleaning process is improved at temperatures of up to 80 °C.

Flow rates and pressure range:

- Flow rates up to 13,000 l/h
- Pressures up to 10 bar

Suitable for following media:

- Bottling of juices and sauces
- Dosage of additives, colouring and flavourings as well as enzymes
- Food such as beverages, dairy products and confectionery
- Yeast pumping
- Oil pumping
- Wine bottling

Certificates:

- The hose of the PERIPRO food version is certified according to:
- 3A

Advantages

- Latest hose material generation (FDA-certified nitrile)
- DIN 11851 or Tri-Clamp connections
- Simple and fast removing the front cover to facilitate CIP cleaning processes
- Front roller removal
- Base and cover made of stainless steel



The Design of PERIPRO

FOR A WIDE RANGE OF CONVEYING TASKS



1 Latest technology of peristaltic pumps

The materials used are compatible with many media. The performance under abrasion, corrosion and temperature requirements are excellent.

2 Saving on hose consumption and ease of installation

Hose with unique manufacturing process: extruded inner layer with high-density textile reinforcement and precisely machined outer layer. Thanks to controlled tolerances, the hose ensures optimal compression and fast installation.

3 Robust construction for the most demanding applications up to 10 bar

Integrated oversized bearings for radial loads, large metal rollers with oversized bearings, safe and reliable connection system and highly robust construction materials for demanding applications.

4 XXL roller technology for fewer energy costs and more efficiency

Due to the size of the rollers, the hose is optimally compressed. This leads to more efficiency, low energy consumption and a better hose life. The starting torque is minimal, and the operation is simple.

5 Front Cover

Easy and quick to remove the front cover to aid CIP cleaning processes.

[Click here for the 3D model:](#)



NETZSCH Barrel/Drum Emptying Units

Our NETZSCH barrel/drum emptying

To empty standard barrels from 20 l to 200 l. Flow rates from approx. 0,1-12 m³/h. Clean emptying, residue without inliner < 1 %.



NETZSCH barrel emptying system NBE 200 in hygienic design and NETZSCH barrel emptying system NBE 20 in industrial design

Advantages

- Efficient emptying of containers of all sizes
- Gentle, low-pulsation and continuous delivery of highly viscous media
- The medium is completely covered while the container is being emptied, so the medium has no contact with the atmosphere: high product safety
- Speed-proportional delivery, with high repeat accuracy, therefore also suitable for dosing
- Ideally suited for loading dispensers and dosing valves
- Pressure maintenance control possible
- Complete heating possible

Accessories

With the right accessories, the NETZSCH pumps can be seamlessly integrated into any process:

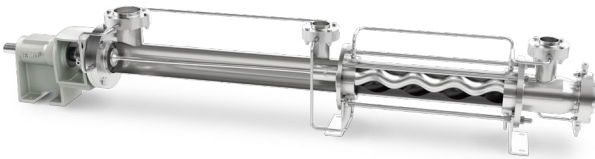

Piping for the aseptic application for the type NEMO® SA aseptic:

All static seals to the atmosphere are double sealed chambers. Sterile condensate, vapour and/or detector fluid is continuously supplied to the chambers. Through this a contamination proof design is ensured.

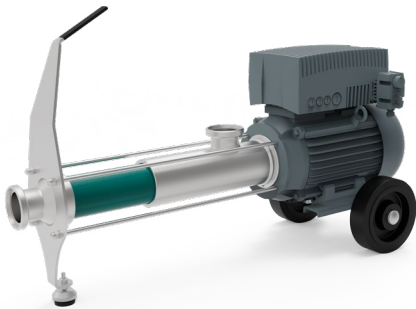

The mobile NEMO® beverage pump

On wheels, the pump can be used universally in viticulture, wineries, cider factories, breweries, distilleries and beverage production. Its advantages guarantee gentle and reliable conveyance of your media; they can be used flexibly in your process, are stable, require little maintenance and are easy to operate.

The mobile version is also optionally available for the TORNADO® rotary lobe pump.

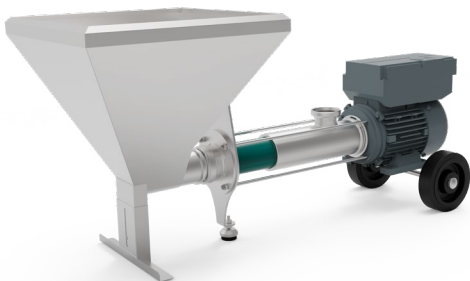

The NEMO® pump with funnel

The funnel facilitates optimal filling of the pump with chunky media such as fruit.

The owner-managed NETZSCH Group is a leading global technology company specializing in mechanical, plant and instrument engineering.

Under the management of Erich NETZSCH B.V. & Co. Holding KG, the company consists of the three business units Analyzing & Testing, Grinding & Dispersing and Pumps & Systems, which are geared towards specific industries and products. A worldwide sales and service network has guaranteed customer proximity and competent service since 1873.

The NETZSCH Business Unit Pumps & Systems offers NEMO® progressing cavity pumps, TORNADO® rotary lobe pumps, NOTOS® multi screw pumps, PERIPRO® peristaltic pumps, macerators/grinders, dosing technology and equipment that are custom built for challenging solutions for different applications globally.

Proven Excellence.■

NETZSCH Pumpen & Systeme GmbH
Geretsrieder Straße 1
84478 Waldkraiburg, Germany
Tel.: +49 8638 630
info.nps@netzsch.com
www.pumps-systems.netzsch.com



NETZSCH®
www.netzsch.com